











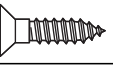
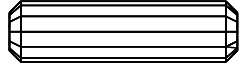

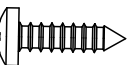

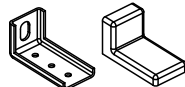





REF. 25785

Monte o móvel como nós o produzimos: COM CARINHO.
Assemble the furniture as we produce it: WITH LOVE.
Armar el mueble como nosotros lo producimos: CON CARIÑO.

FERRAGENS / HARDWARE LIST / LISTA DE HERRAJES

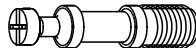
Os desenhos das ferragens são em escala real, então suas dimensões são iguais as das ferragens reais.
The hardware drawings are full-scale, so their dimensions are the same as the actual hardware.
Los dibujos de los herrajes son la escala real, por lo que sus dimensiones son las mismas que las del herraje real.

ID	IMAGEM DE REFERÊNCIA / IMAGE REFERENCE IMAGEN REFERENCIA	QUANTIDADE # OF PIECES CANTIDAD
A	  4,5x45mm	04
B	  3,5x14mm	23
C	 8x30mm	24
D	  4,5x14mm	12
E	 5x8	06
F		02
G		02
H	 1/4x1 1/2"	02
I	  5,0x70mm	06
J	  M6x20mm	04
K	  4,5x22mm	02
L	  4,5x35mm	01
M		04
N		04
O		04

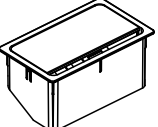
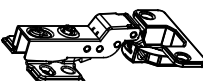
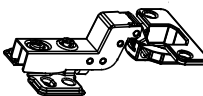
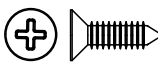

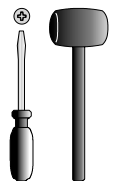
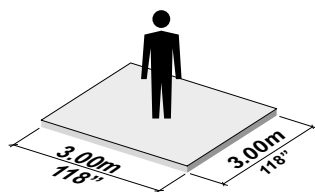
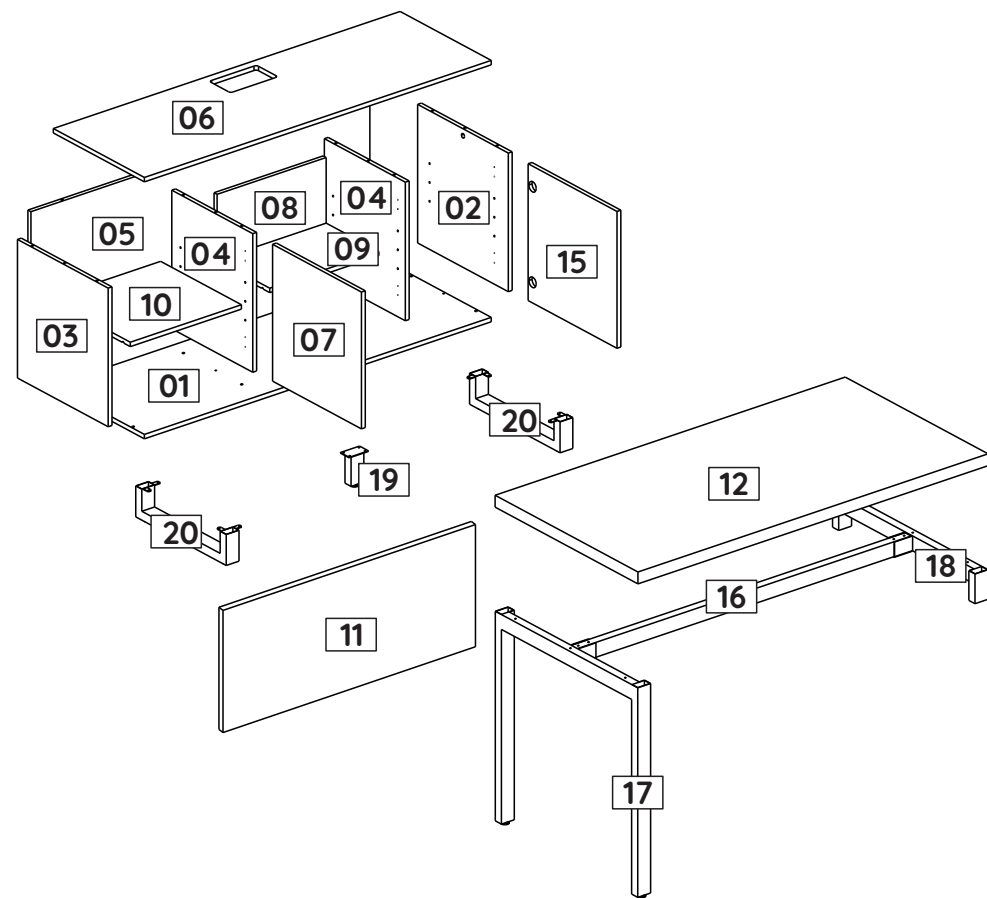
ID	IMAGEM DE REFERÊNCIA / IMAGE REFERENCE IMAGEN REFERENCIA	QUANTIDADE # OF PIECES CANTIDAD
P		07
Q		01
R	 CURVA	02
S	 SUPER CURVA	02
T	 3,5x12mm	04

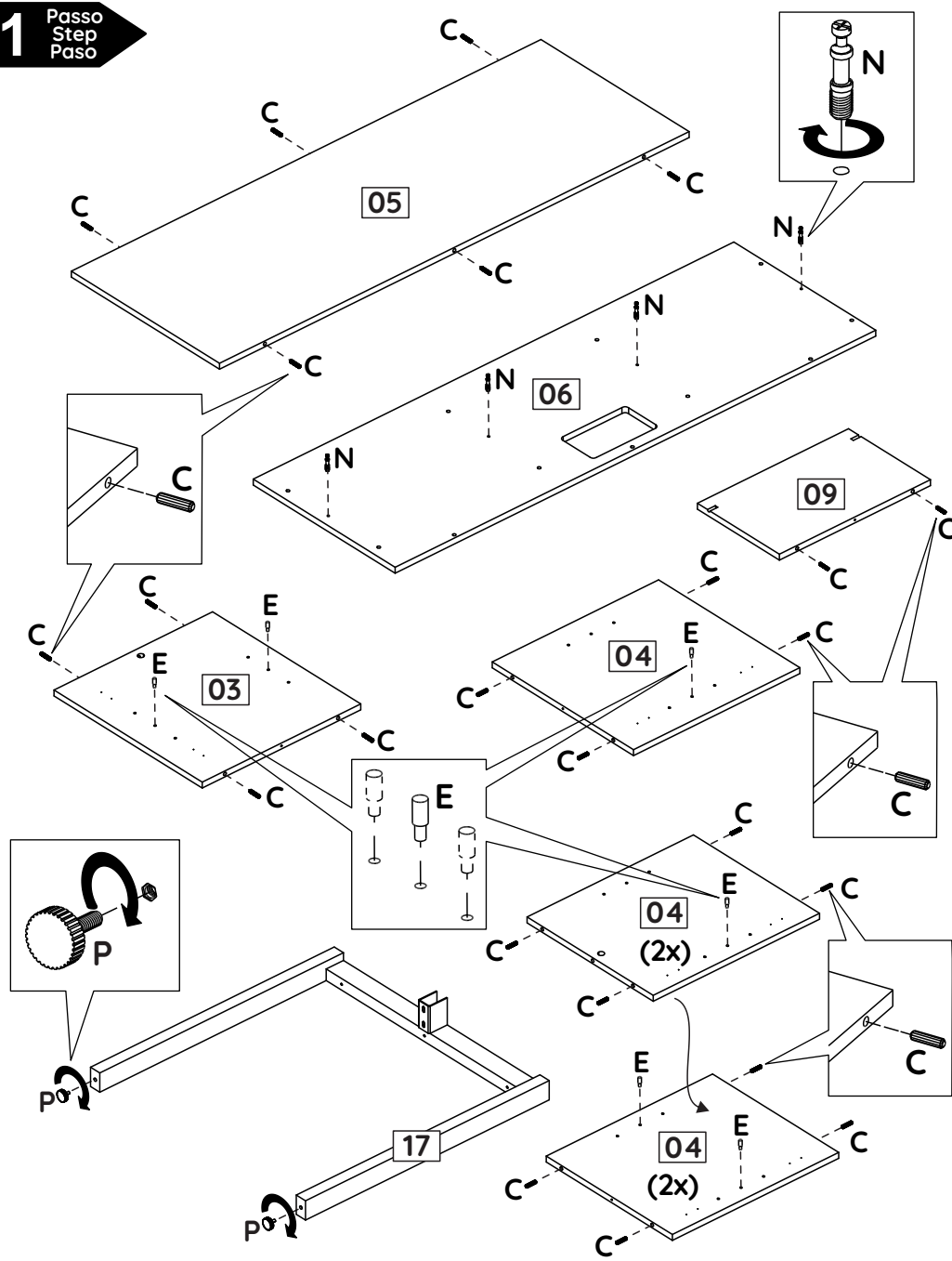

ID	Descrição / Description / Denominación	Quantidade # Of Pieces Cantidad	Dimensão (mm) Dimension (mm) Dimensión (mm)
01	Base/Base/Base	01	1358x450x15
02	Lateral esquerda/Left side/Lateral izquierda	01	470x448x15
03	Lateral direita/Right side/Lateral derecha	01	470x448x15
04	Division/División	02	470x400x15
05	Back/Revés	01	1327x470x15
06	Top/Tapa	01	1360x450x15
07	Central door/Puerta central	01	464x439x15
08	False Bottom/Fondo falso	01	465x427x15
09	Shelf/Repisa	01	427x260x15
10	Side shelf/Repisa lateral	01	435x396x15
11	Panel table/Panel mesa	01	830x360x15
12	Top table/Tapa mesa	01	1362x702x15
15	Side panel/Porta lateral	01	464x439x15
16	Table traverse/Travesaño mesa	01	1292x50x30
17	Foot/Pata	01	700x725x50
18	Central support table/Pata apoio mesa	01	700x100x50
19	Central support foot/Pata apoio central	01	60x60x115
20	Side foot/Pata lateral	02	450x50x115

1 Passo Step Paso

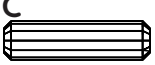
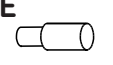
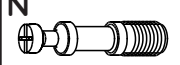

- C**

 (24x)
- E**

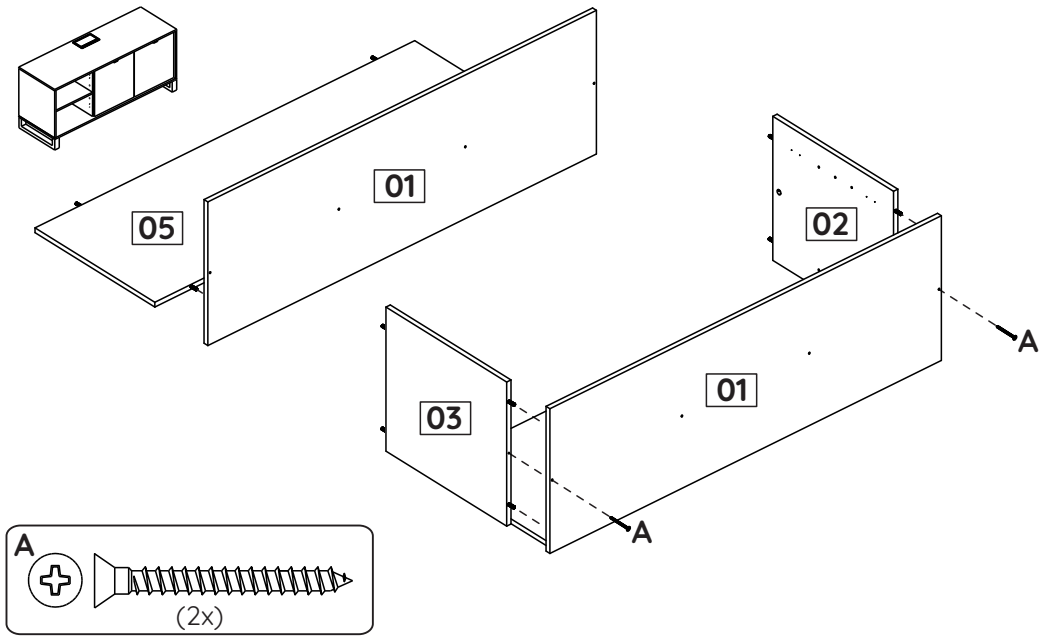
 (6x)
- N**

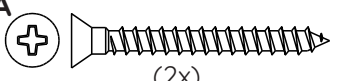
 (4x)
- P**

 (2x)

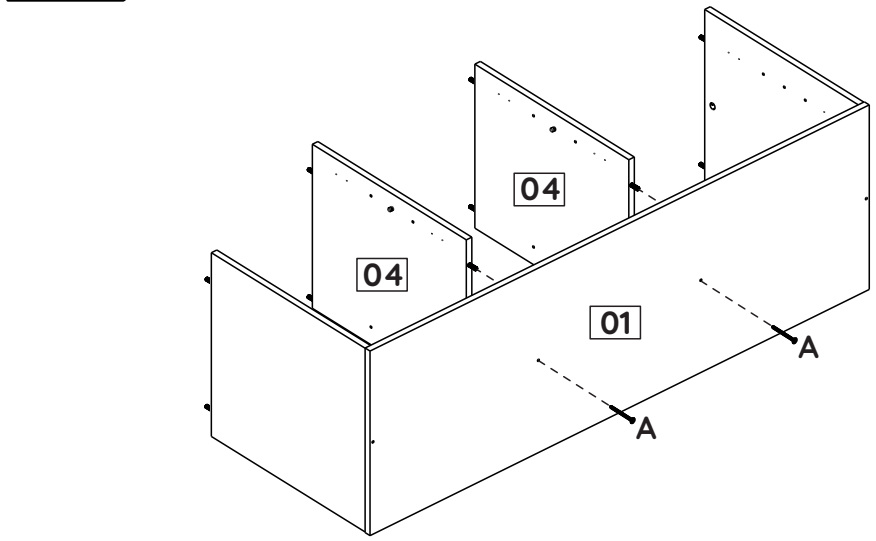
2 Passo Step Paso



- A**

 (2x)

3 Passo Step Paso

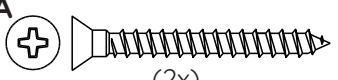

- A**

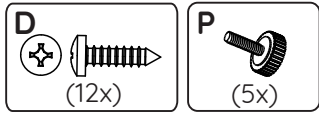
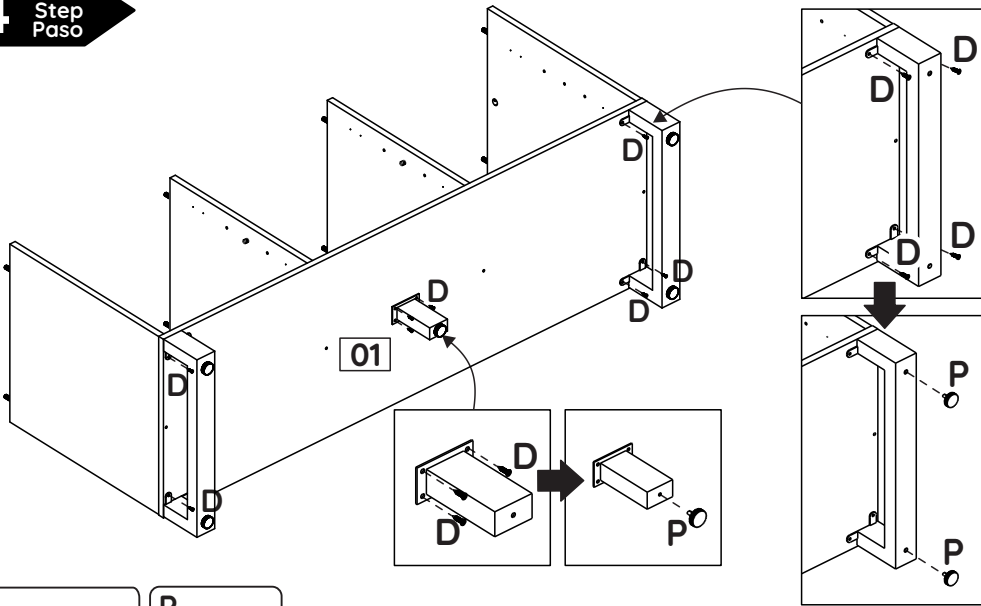
 (2x)

4 Passo
Step
Paso

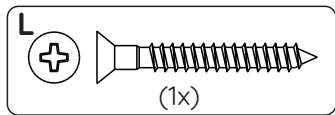
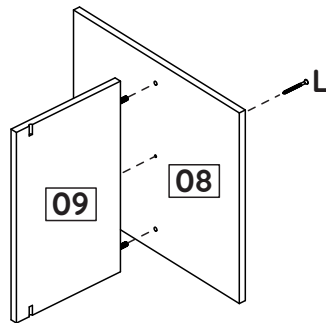

5 Passo
Step
Paso



6 Passo
Step
Paso

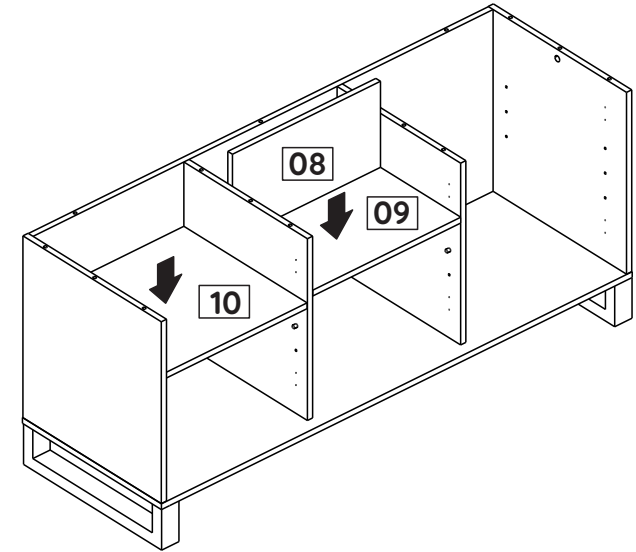

7 Passo
Step
Paso

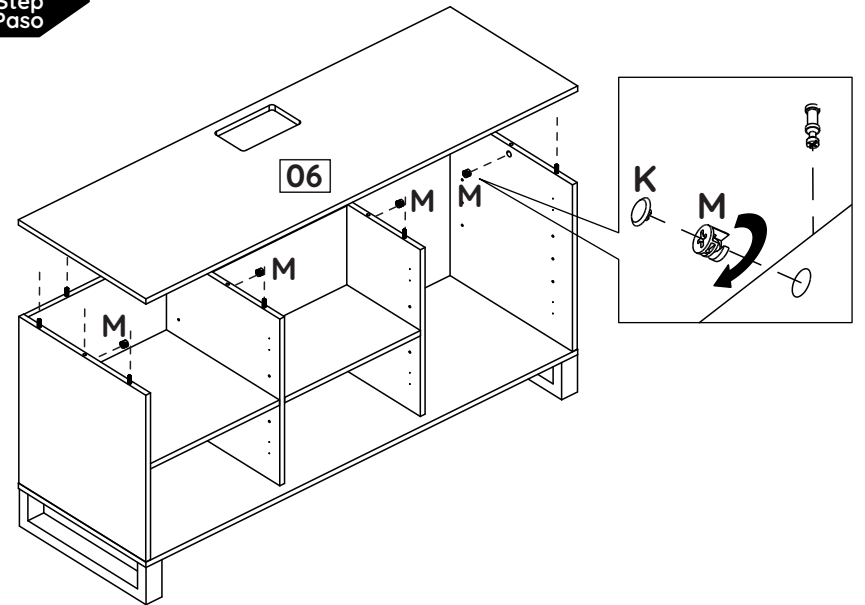

8 Passo
Step
Paso

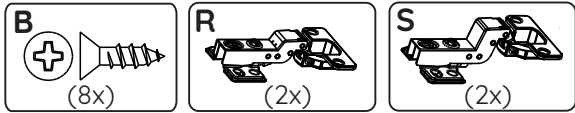
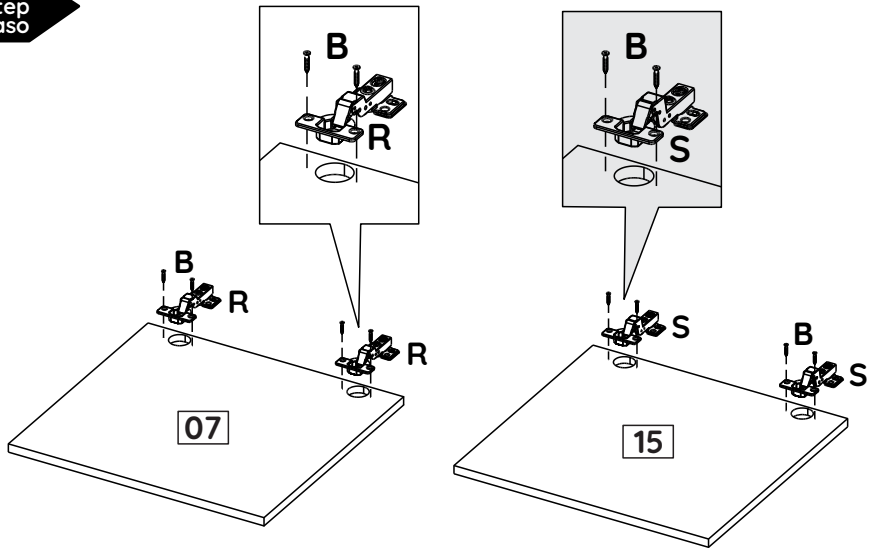

9 Passo
Step
Paso

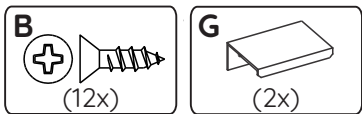
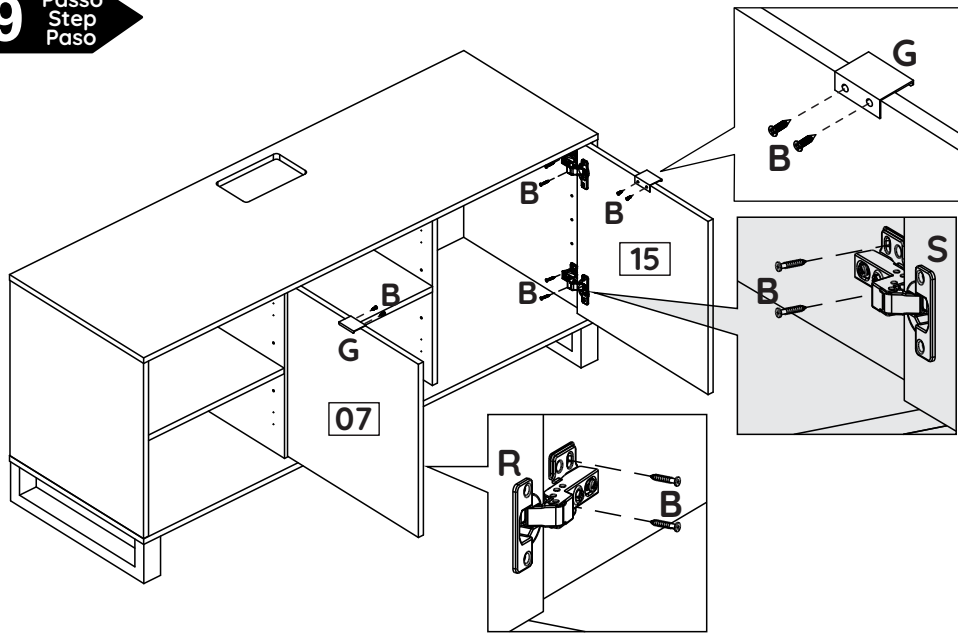

10 Passo
Step
Paso

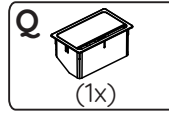
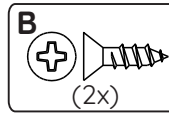
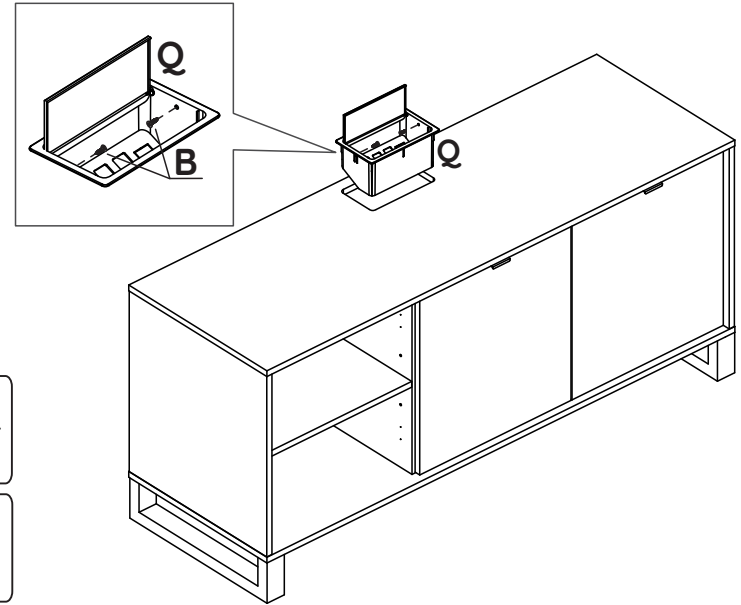

11 Passo
Step
Paso

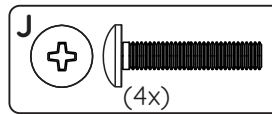
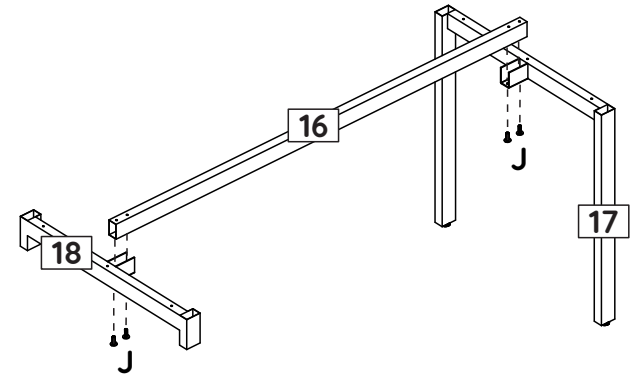
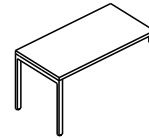

12 Passo
Step
Paso

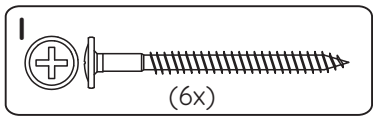
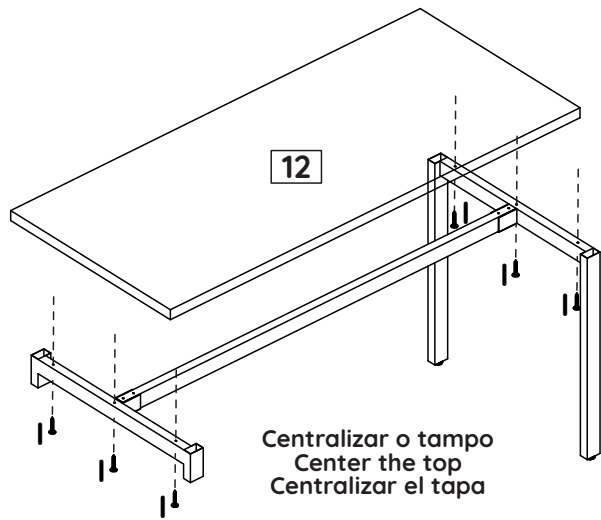

13 Passo
Step
Paso

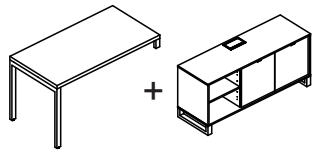

Broca Ø8mm
Drill Ø8mm
Taladro Ø8mm

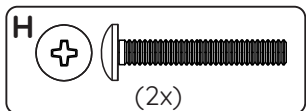
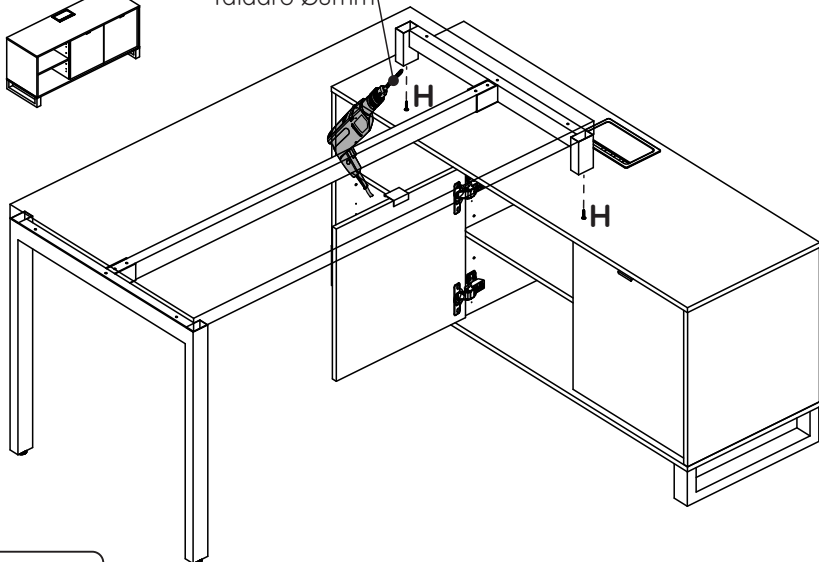

14 Passo
Step
Paso

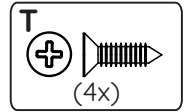
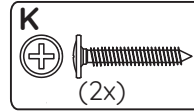
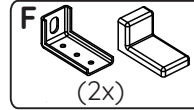
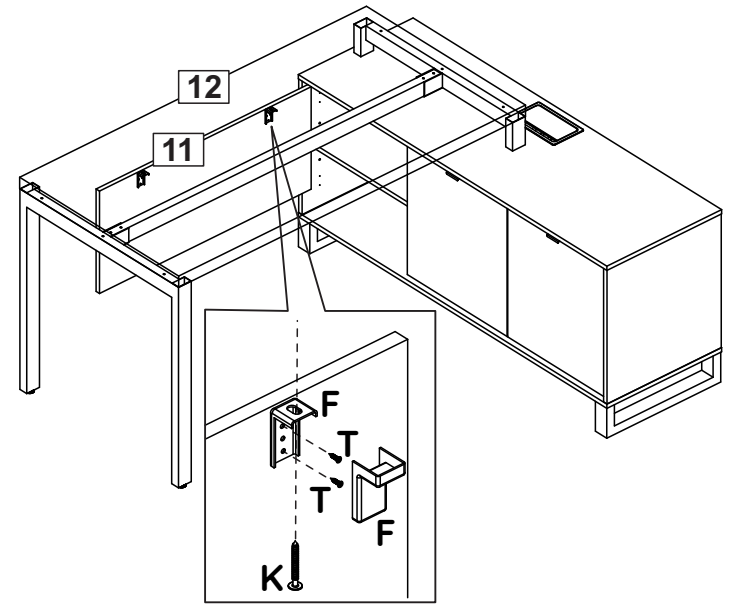

15 Passo
Step
Paso

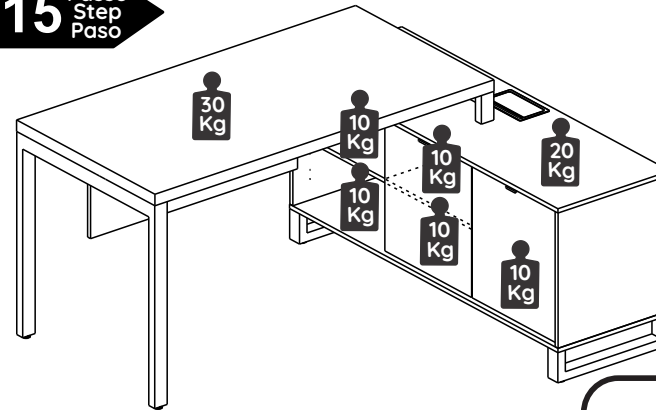



100Kg

PESO MÁXIMO SUPORTADO
MAXIMUM WEIGHT SUPPORTED
PESO MAXIMO SOPORTADO

Dicas de Conservação / Maintenance Tips / Consejos de Mantenimiento

*Para limpar ou tirar manchas, utilize uma flanela umedecida em solução de água e álcool, na mesma proporção. Evite exposição ao sol.

*To clean or remove stains, use a piece of flannel dampened with a water and alcohol solution, in the same proportion. Avoid direct sunlight.

*Para limpiar o sacar manchas, utilice una flanela humedecida en solución de agua y alcohol, en la misma proporción. Evite la exposición directa al sol.