

④ Montagem das Costas

06 - Montagem da Régua da Parede Superior/Inferior;

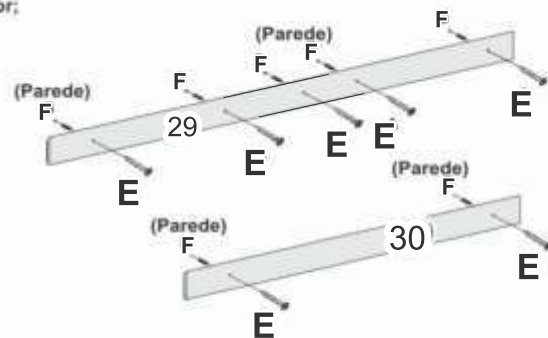
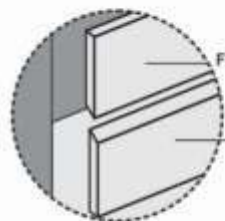

05 - Aspecto Final

ATENÇÃO SR. MONTADOR

Passar a fita de LED pelo furo da peça (03), depois colar atrás do painel fresado (01).

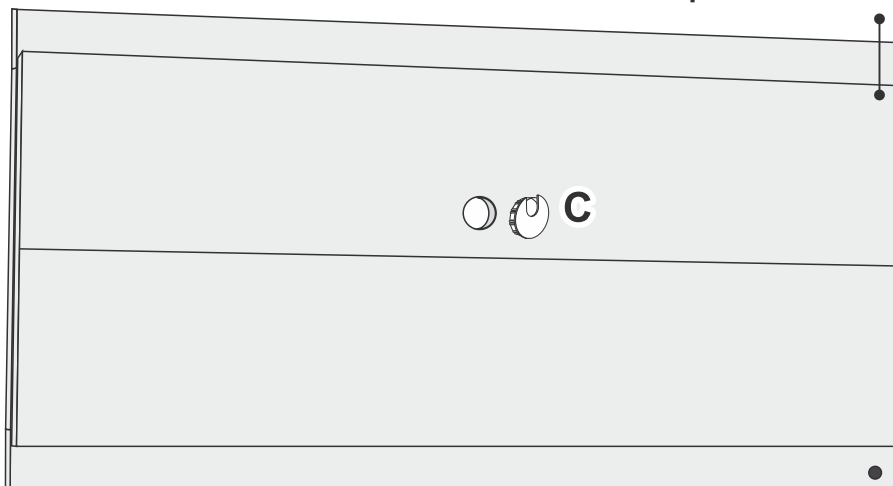

PAINEL ISTAMBUL / ROMA

CÓDIGO: 5407

CÓDIGO: 9069

m Mavaular
MÓVEIS

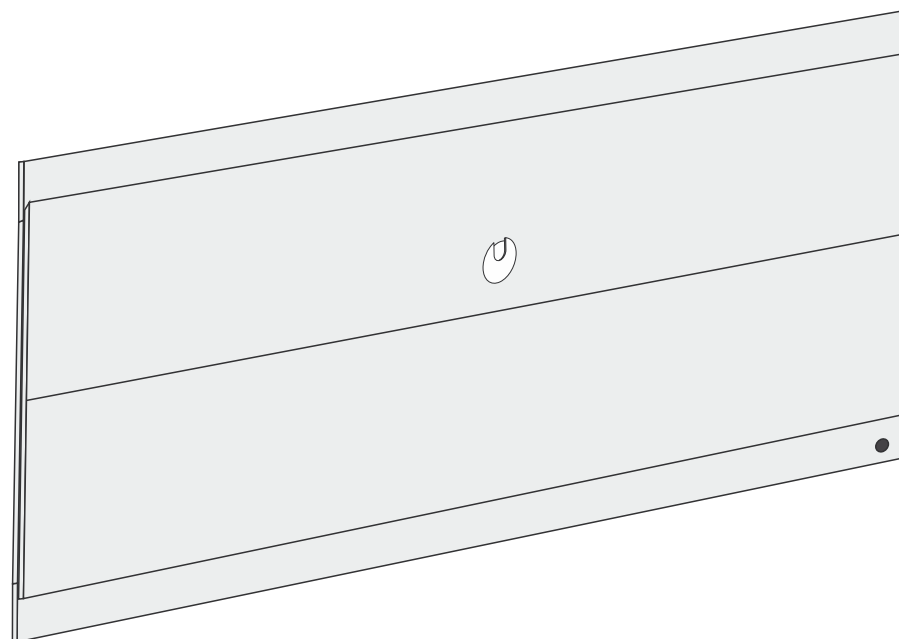

Lista de peças/Lista de piezas/Parts list

Nº	PEÇAS	PARTES	PARTS
20	Painel Superior Central Fresado	Panel Superior Central Fresado	Top Panel Central Milling
21	Painel Inferior Central	Panel central inferior	Central Bottom Panel
22	Painel Superior	Panel Superior	Top Panel
23	Laterais do Painel	Del Panel	Panel Side
24	Painel Inferior	Panel Inferior	Lower Panel
25	Régua Superior Fresada	Regla Superior Fresada	Milling Upper Ruler
26	Réguas Laterais	Reglas Laterales	Lateral Rulers
27	Régua de união	Regla de unión	Union Ruler
28	Régua Inferior Fresada	Regla Inferior Fresada	Milling Bottom Ruler
29	Moldura da Parede Maior	Marco de la Pared Mayor	Larger Wall Frame
30	Moldura da Parede Menor	Marco de Pared Menor	Small Wall Frame

✓ Atualizado em:
01/12/2021

Lista de peças/Lista de piezas/Parts list

	ACESSÓRIOS	ACCESRIOS	ACCESORIES		QTD.
A	Parafuso 4,5 x 25	Tornillo 4,5 x 25	Screw 4.5 x 25		55
B	Cavilha 6x25	Cuchillo 6x25	6x25 Bolt		04
C	Passa Fio	Pasa Hilo	Thread Tools		01
D	Cola sachê	Cola sachê	Sachet		02
E	Parafuso 4,8x4,5	Tornillo 4,8x4,5	Screw 4,8x4,5		07
F	Bucha Plástica	Banda Plástica	Plastic loofah		07
G	Fita de LED	Cinta de LED	LED tape		01

01- Início da Montagem

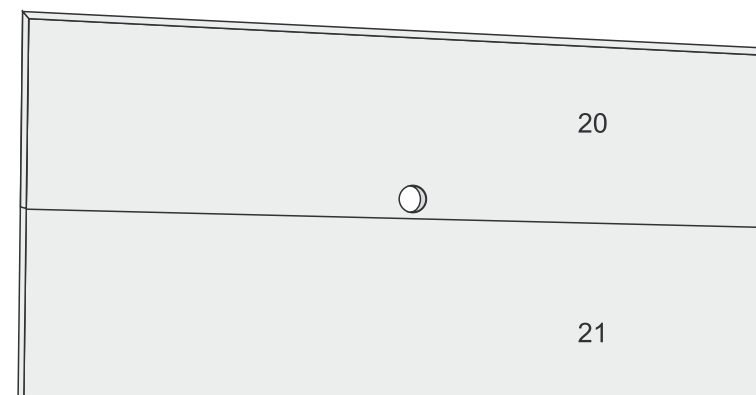

02 - Montagem dos painéis inferior, superior e lateral.

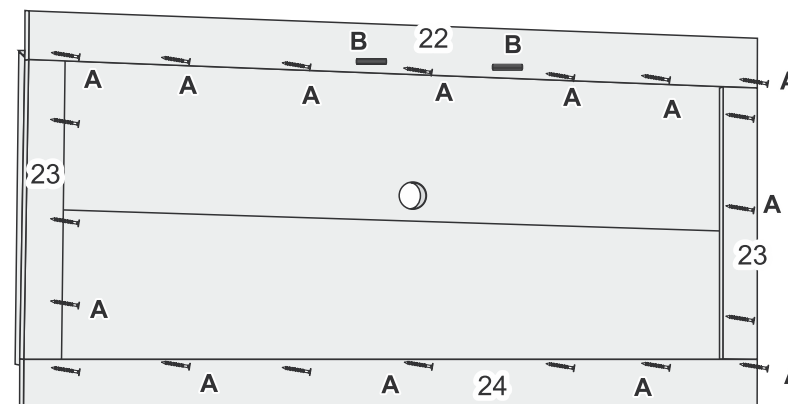

03 - Montagem das réguas

Obs.: Usar cola nas peças 6 e 9

