

ASSEMBLY INSTRUCTIONS MANUAL DE MONTAGEM / INSTRUCCIONES DE ARMADO

Évora kitchen
Cozinha Évora
Cocina Évora

Reference 200085 | Revisão 01
Referência 200085 | Revisão 01
Referencia 200085 | Revisión 01

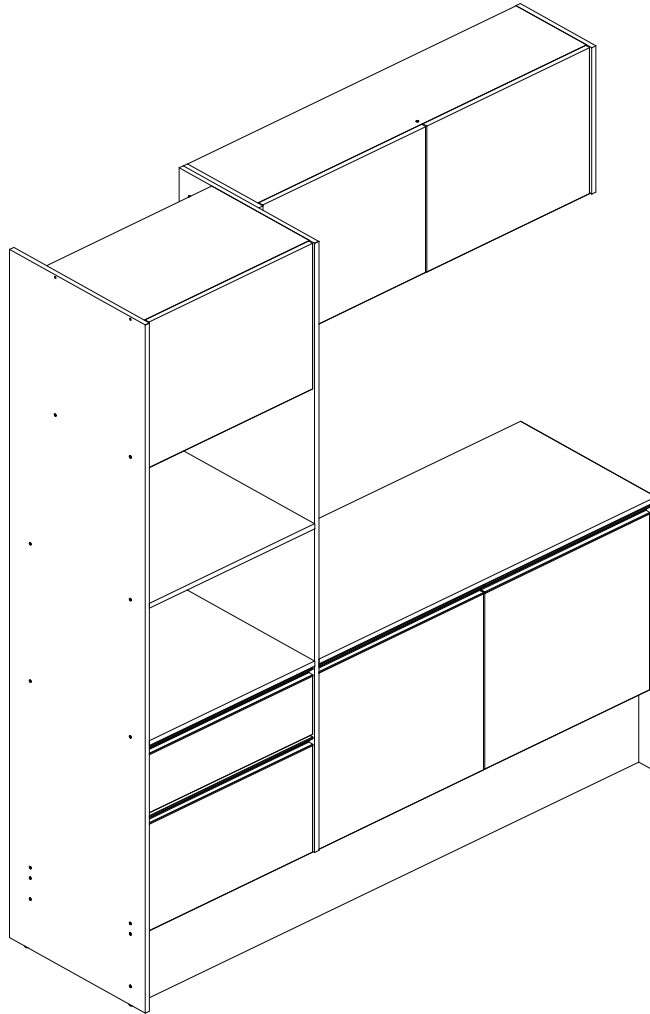

YOU WILL NEED / VOCÊ VAI PRECISAR DE / USTED NECESITARÁ

Tools not supplied / Ferramentas não fornecidas / Herramientas no incluidas

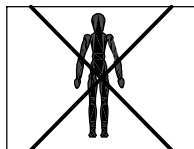

1 Person
1 Pessoa
1 Persona

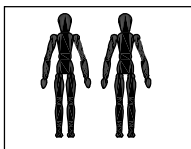

2 People
2 Pessoas
2 Personas

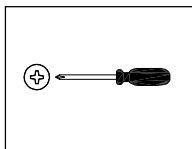

Screwdriver Phillips
Chave Phillips
Destornillador cruz

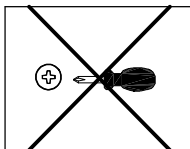

Small screwdriver Phillips
Chave Phillips Menor
Destornillador cruz menor

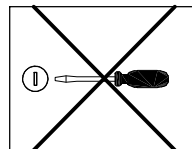

Screwdriver slotted
Chave fenda
Destornillador plano

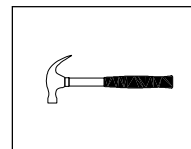

Hammer
Martelo
Martillo

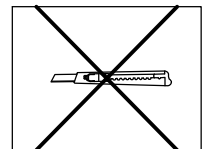

Stilet
Estilete
Estilete

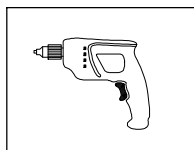

Drill machine
Furadeira
Taladro

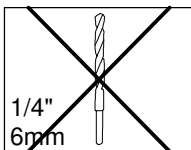

Drill bit
Broca
Taladro

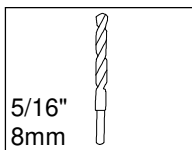

Drill bit
Broca
Taladro

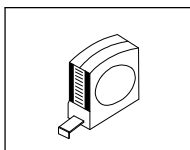

Measuring tape
Trena
Cinta de medición

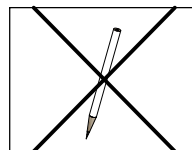

Pencil
Lápis
Lápis

NOTES: The separation of the accessories before you start the assembly will facilitate the same. In case of doubt on the size of the screws and bolts, use the ruler to bottom of page 3.

NOTAS: A separação dos acessórios antes de iniciar a montagem facilitará a mesma. Em caso de dúvida no tamanho dos parafusos e cavilhas, utilize a régua ao final da página 3.

NOTAS: La separación de los accesorios antes de comenzar el armado facilitará el mismo. En caso de duda sobre el tamaño de los tornillos y taquetes, utilice la regla al pie de página 3.

MAXIMUM RECOMMENDED WEIGHT
BEING THIS EVENLY DISTRIBUTED

PESO MÁXIMO RECOMENDADO SENDO
ESTE DISTRIBUÍDO UNIFORMEMENTE

PESO MÁXIMO RECOMENDADO SIENDO
ESTE UNIFORMEMENTE DISTRIBUIDO

	LB	KG
A	11	5
B	22	10
C	6,6	3

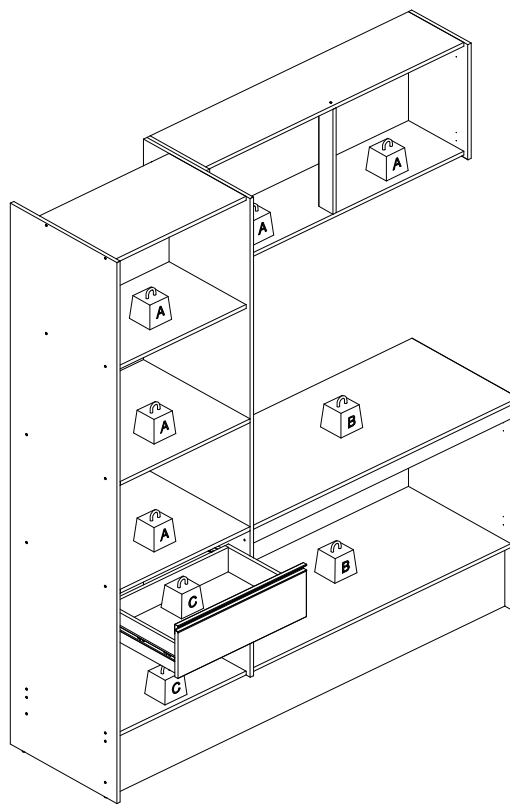





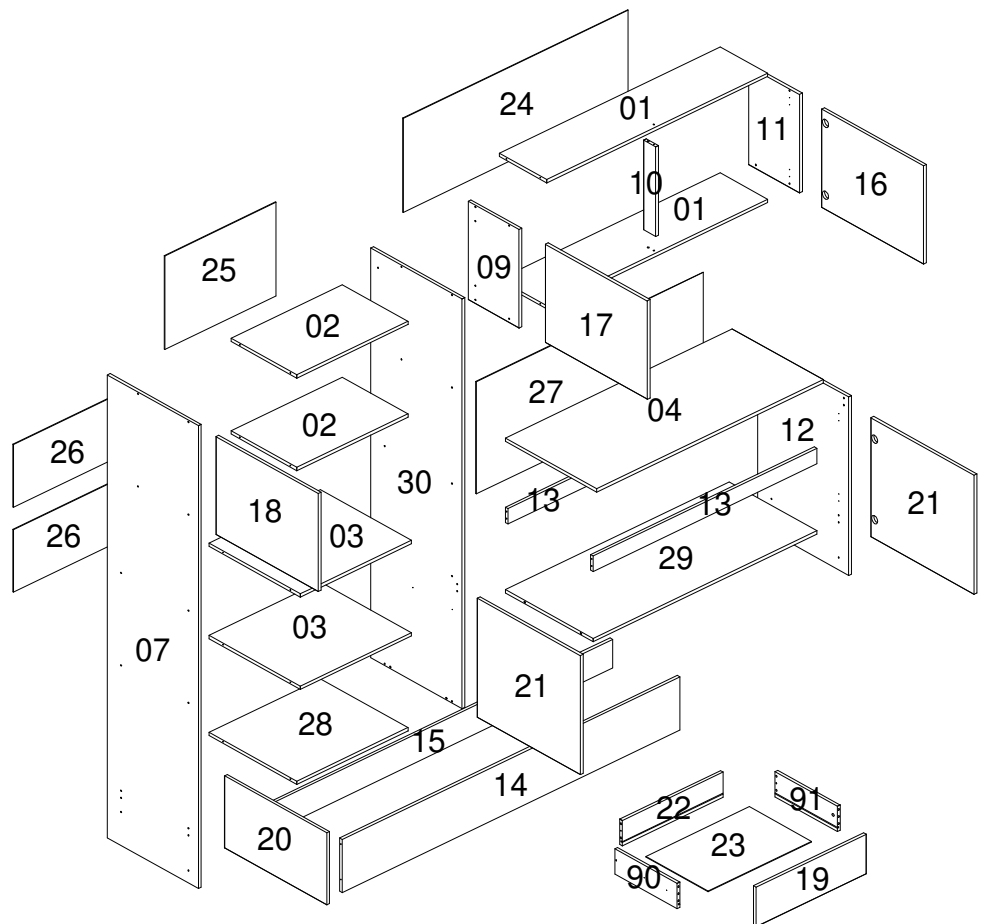







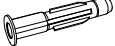

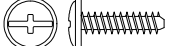
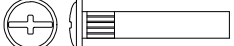

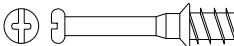

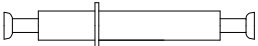

Nº	Measures Inches	Medidas cm	Qty./Qtd.
01	46 1/8 x 10 5/8 x 5/8	117,1 x 27 x 1,5	2
02	14 3/4 x 23 1/4 x 5/8	37,5 x 58,9 x 1,5	2
03	20 1/2 x 23 1/4 x 5/8	52 x 58,9 x 1,5	2
04	20 1/2 x 47 3/8 x 5/8	52 x 120,2 x 1,5	1
08	73 1/4 x 20 1/2 x 5/8	185,9 x 52 x 1,5	1
09	11 3/8 x 17 5/8 x 5/8	29 x 44,7 x 1,5	1
10	16 x 2 3/4 x 5/8	40,7 x 7 x 1,5	1
11	11 3/8 x 17 5/8 x 5/8	29 x 44,7 x 1,5	1
12	31 7/8 x 20 1/2 x 5/8	81 x 52 x 1,5	1
13	46 3/4 x 2 3/4 x 5/8	118,6 x 7 x 1,5	2
14	9 1/2 x 70 1/2 x 5/8	24,1 x 179 x 1,5	1
15	5 1/8 x 70 1/2 x 5/8	13 x 179 x 1,5	1
16	17 1/2 x 22 7/8 x 5/8	44,6 x 58,1 x 1,5	1
17	17 1/2 x 22 7/8 x 5/8	44,6 x 58,1 x 1,5	1
18	17 1/2 x 23 x 5/8	44,5 x 58,3 x 1,5	1
19	7 1/8 x 23 x 5/8	18 x 58,3 x 1,5	1
20	13 1/8 x 23 x 5/8	33,3 x 58,3 x 1,5	1
21	21 1/4 x 23 1/8 x 5/8	54 x 58,8 x 1,5	2
22	21 x 4 1/2 x 5/8	53,4 x 11,5 x 1,5	1
23	21 5/8 x 13 7/8 x 1/8	54,8 x 35,4 x 0,3	1
24	46 7/8 x 16 3/4 x 1/8	119,1 x 42,7 x 0,3	1
25	23 1/4 x 16 3/4 x 1/8	58,9 x 42,5 x 0,3	1
26	23 7/8 x 11 1/8 x 1/8	60,6 x 28,4 x 0,3	2
27	47 3/8 x 20 x 1/8	120,3 x 50,9 x 0,3	1
28	23 1/4 x 19 5/8 x 5/8	58,9 x 50 x 1,5	1
29	46 3/4 x 19 5/8 x 5/8	118,6 x 50 x 1,5	1
30	82 5/8 x 20 1/2 x 5/8	210 x 52 x 1,5	1
90	14 x 4 1/2 x 5/8	35,5 x 11,5 x 1,5	1
91	14 x 4 1/2 x 5/8	35,5 x 11,5 x 1,5	1

PARTS IDENTIFICATION
IDENTIFICAÇÃO DAS PEÇAS / IDENTIFICACIÓN DE LAS PIEZAS

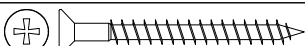
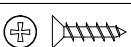

IDENTIFICATION OF ACCESSORIES IDENTIFICAÇÃO DOS ACESSÓRIOS/ IDENTIFICACIÓN DE ACCESORIOS

A		Flanged head screw / Parafuso flangeado / Tornillo de cabeza flangeada	5,0x60 mm	3
A1		Glue / Cola / Pegamento	13 g	1
A2		Small plastic foot / Sapata redonda / Pie plástico	14 mm	4
A4		Metalic bracket / Cantoneira de metal / Soporte de metal	22x22 mm	4
A6		"H" profile / Perfil "H" / Perfil "H"	-	1
B3		Bushing / Bucha expansiva / Tapón	8x50 mm	3
C1		Metal claw / Garra de metal / Garra metal	-	4
E		Wooden dowel / Cavilha / Taquete	8x30 mm	10
E1A		Union flanged head screw / Pf. união flangeado / Tornillo unión flangeado	4,0x10 mm	2
E1B		Union flanged head screw / Pf. união flangeado / Tornillo unión flangeado	30 mm	2
i13		Telescopic slide / Corrediça telescópica / Corredera telescópica	350 mm	2
J		Simple minifix screw / Haste minifix simples / Tornillo minifix simple	-	2
J12		Plastic bracket / Cantoneira plástica / Soporte de plástico	20x20 mm	4
K		Double minifix screw / Haste minifix dupla / Tornillo minifix doble	60mm	2
L		Drum lock / Tambor minifix / Tambor minifix	12 mm	6
M		Bore patch adhesive / Tapa furo adesivo / Tapones adhesivo	-	2
M12		Metal hinge super hight / Dobradiça super alta / Bisagra alta	35 mm	12
M15		Handle / Puxador Perfil MOV4040 / Tirador	588 mm	2
M16		Handle / Puxador Perfil MOV4040 / Tirador	583 mm	2
N5		Support "L" / Suporte "L" / Soporte "L"	-	3
N6		Cover / Capa / Cubierta	-	3
O		Flat head screw / Parafuso chato / Tornillo de cabeza plana	4,5x45 mm	48
P5		Flat head screw / Parafuso chato especial / Tornillo de cabeza plana	3,5x14 mm	12
S		Pan head screw / Parafuso panela / Tornillo de pan	3,5x14 mm	78
X6		Nail / Prego / Clavo	10 x 7	102



PRE-ASSEMBLE
PRÉ-MONTAGE / PRE ARMADO

01

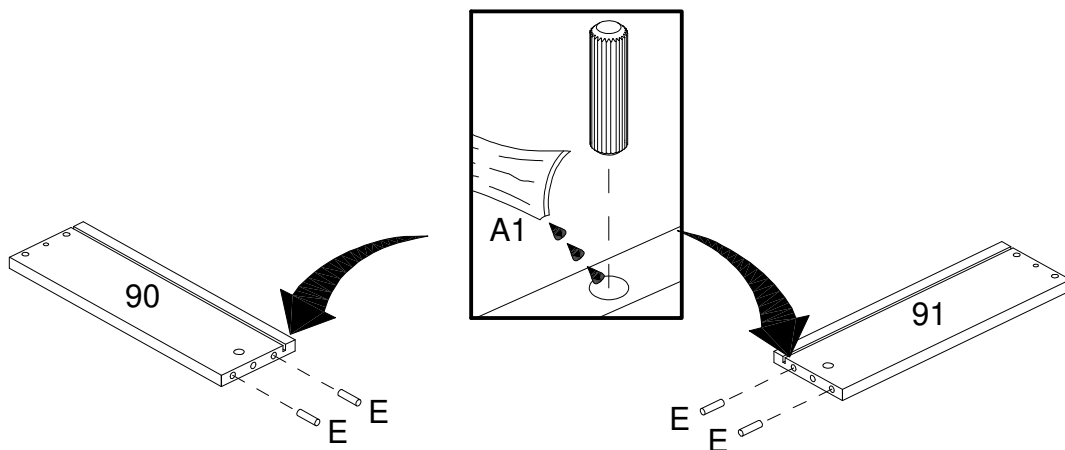
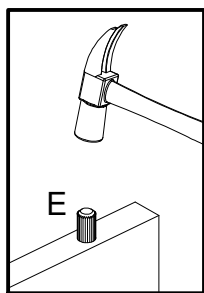

02

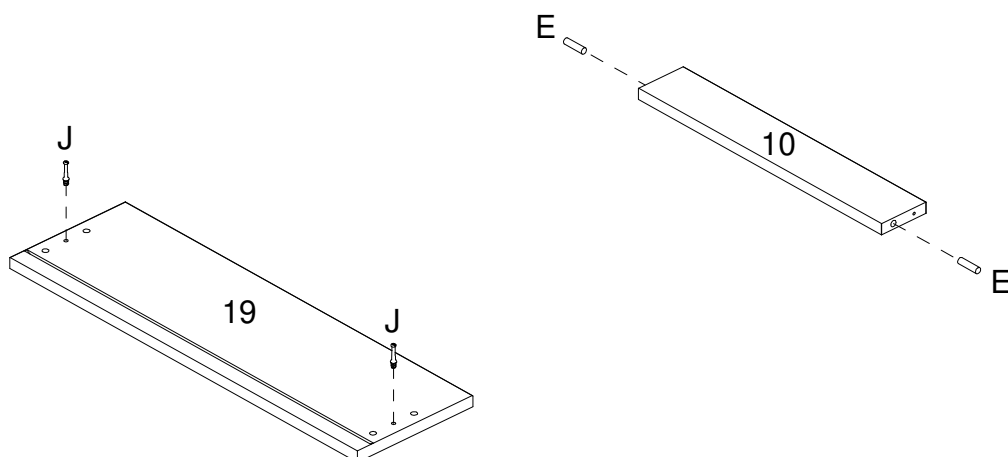
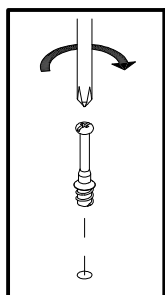

03

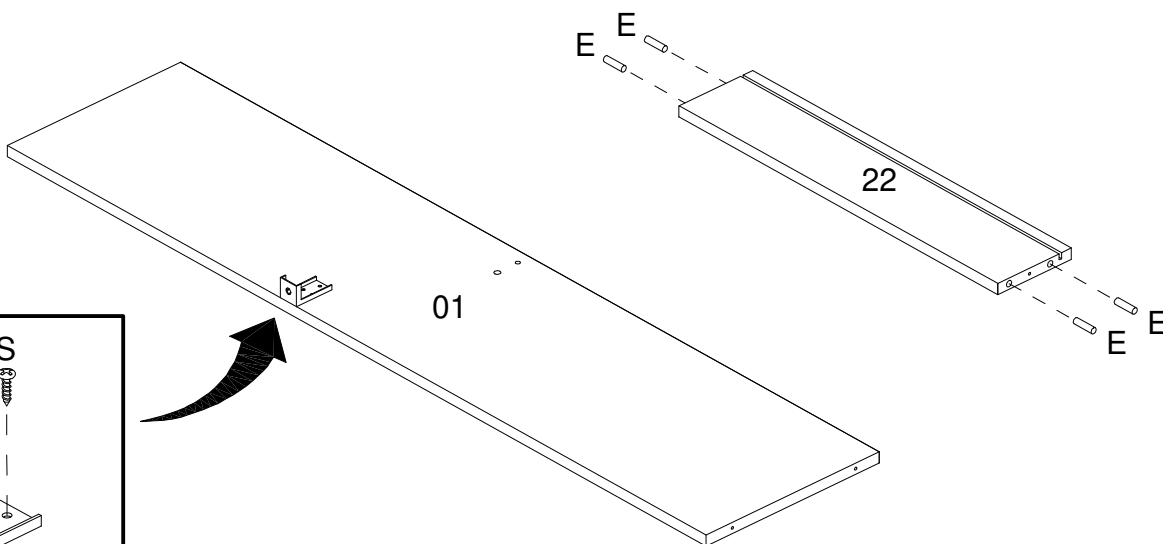
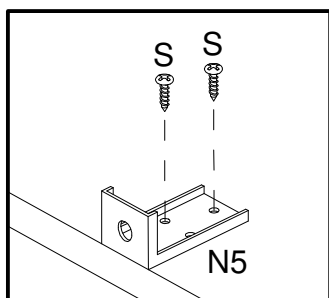

04

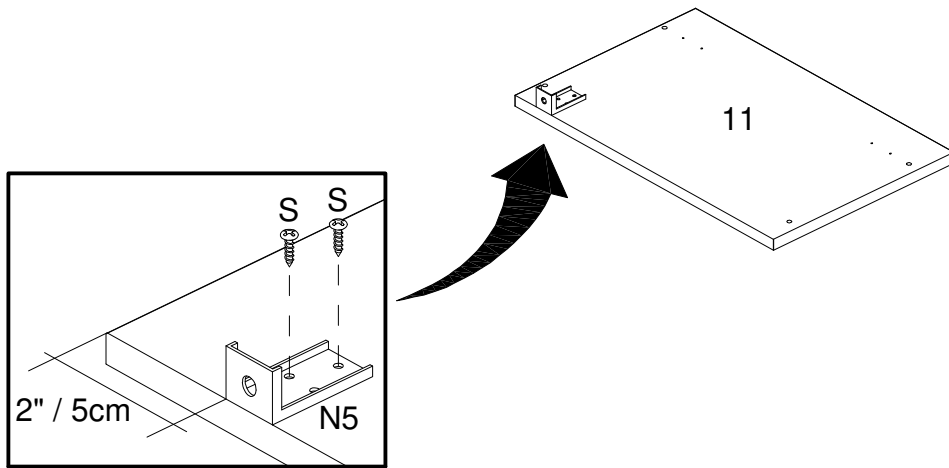

05

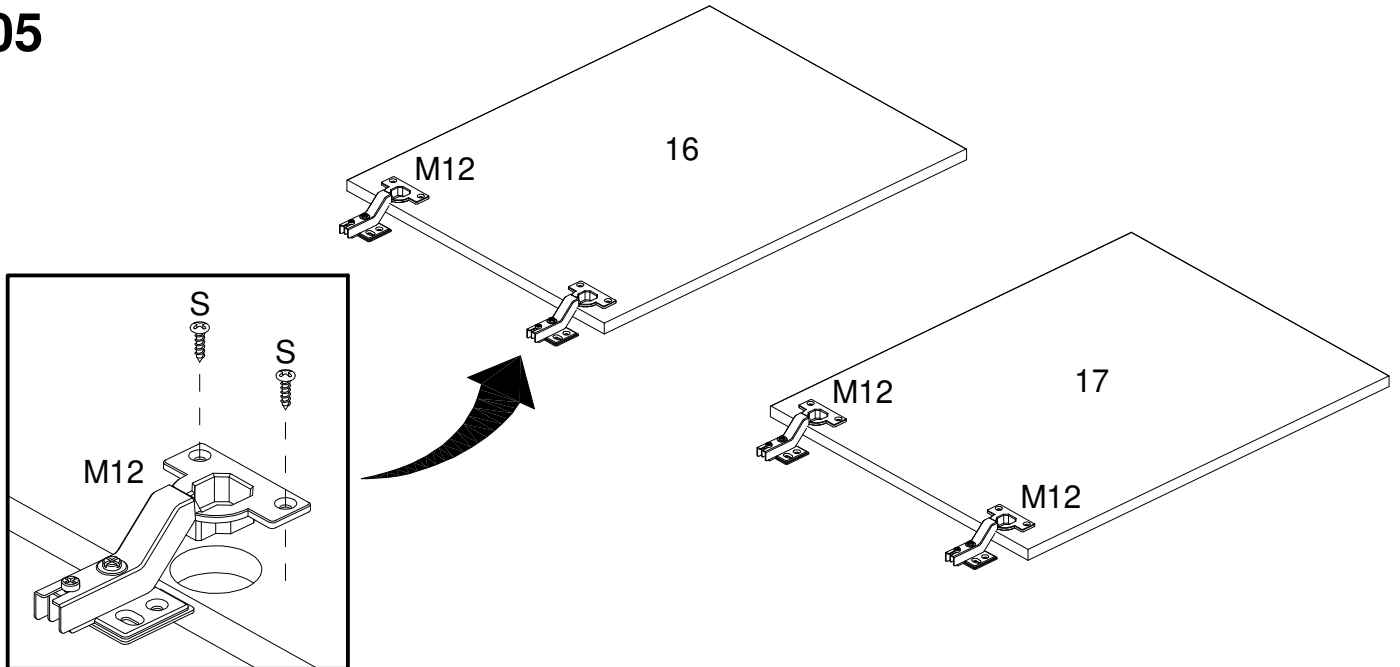

06

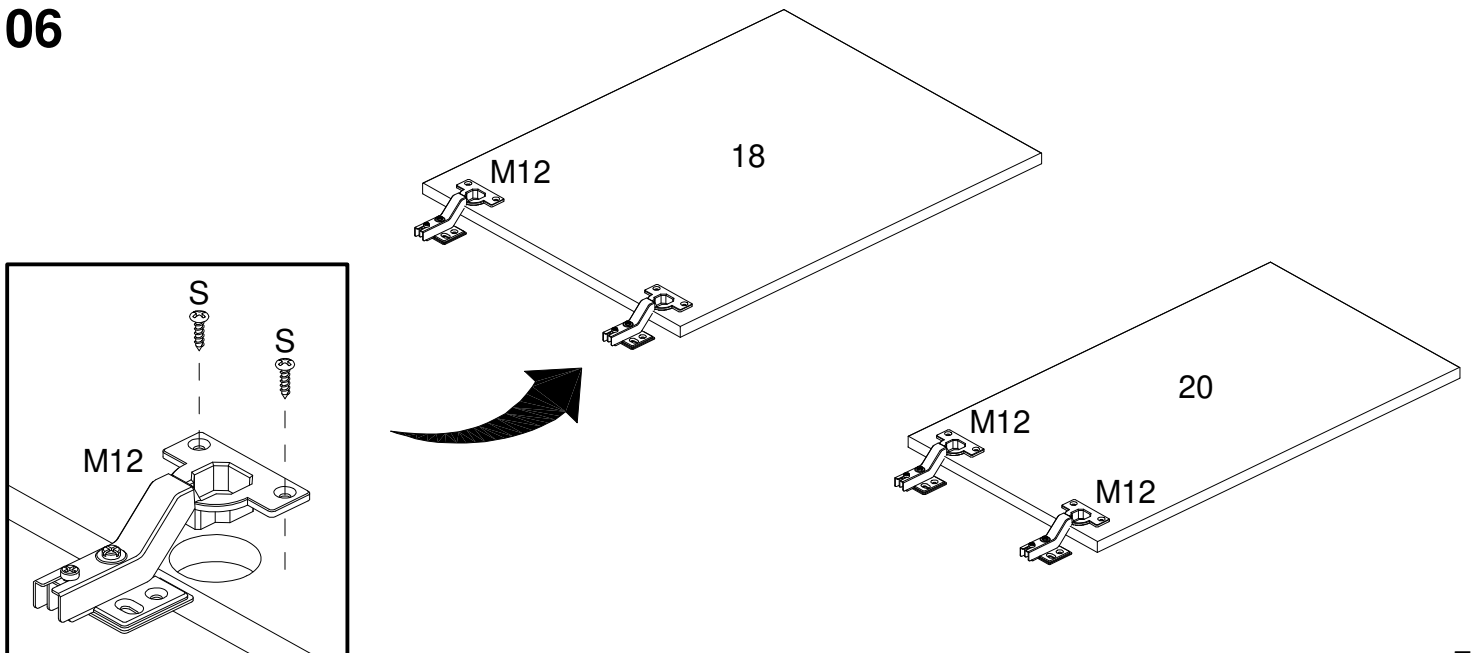

07

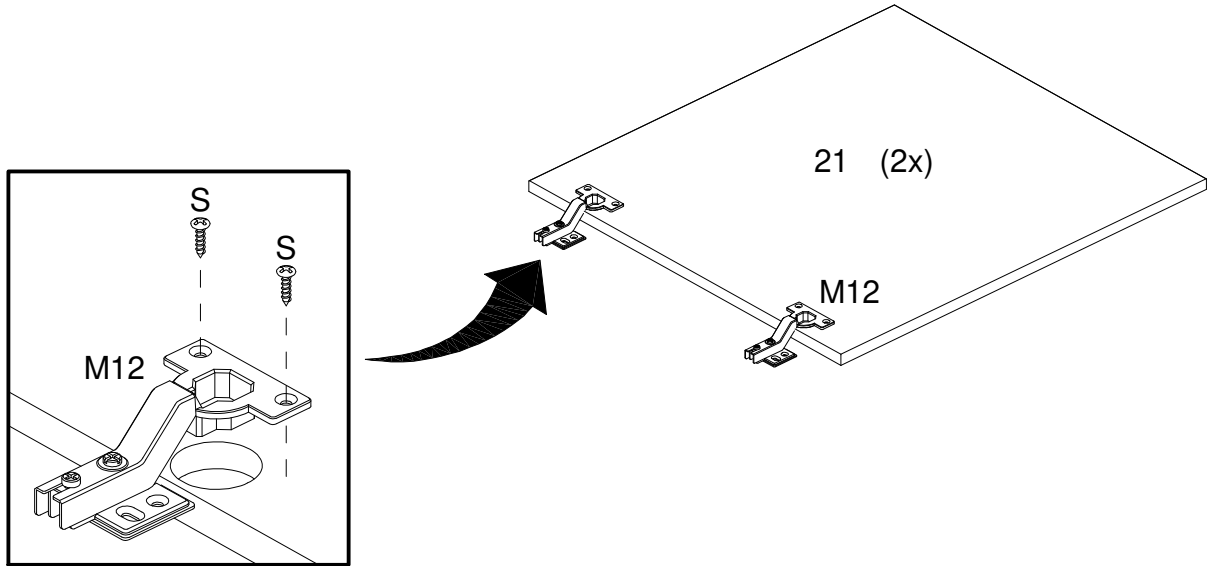

08

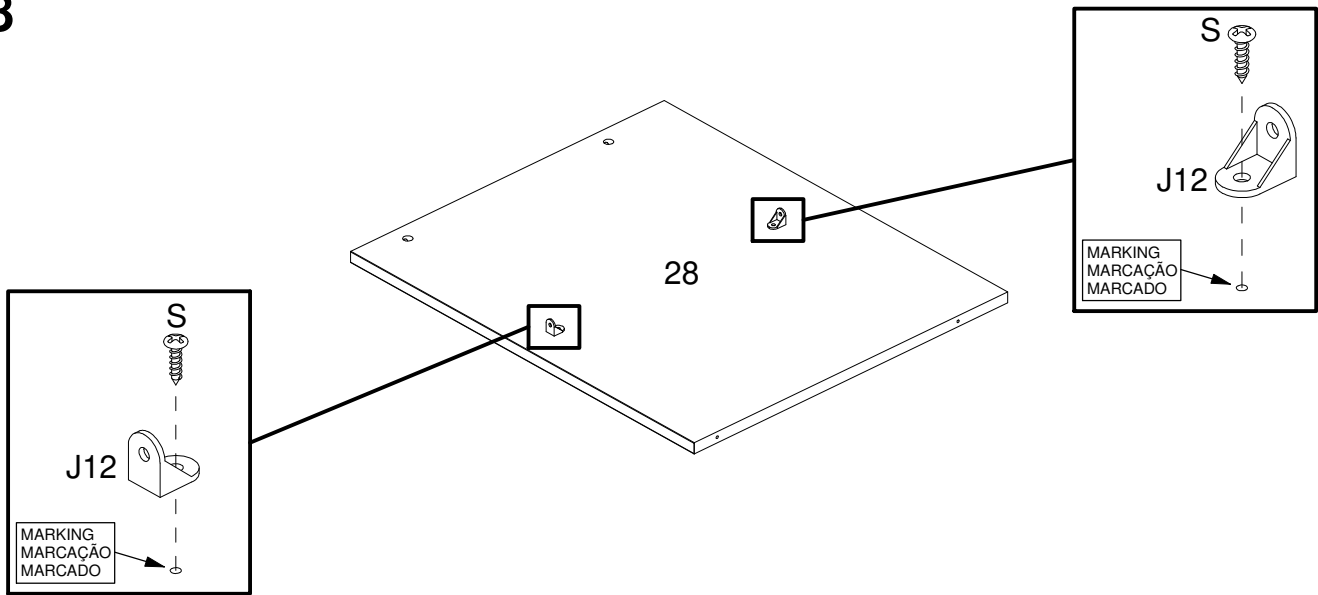

09

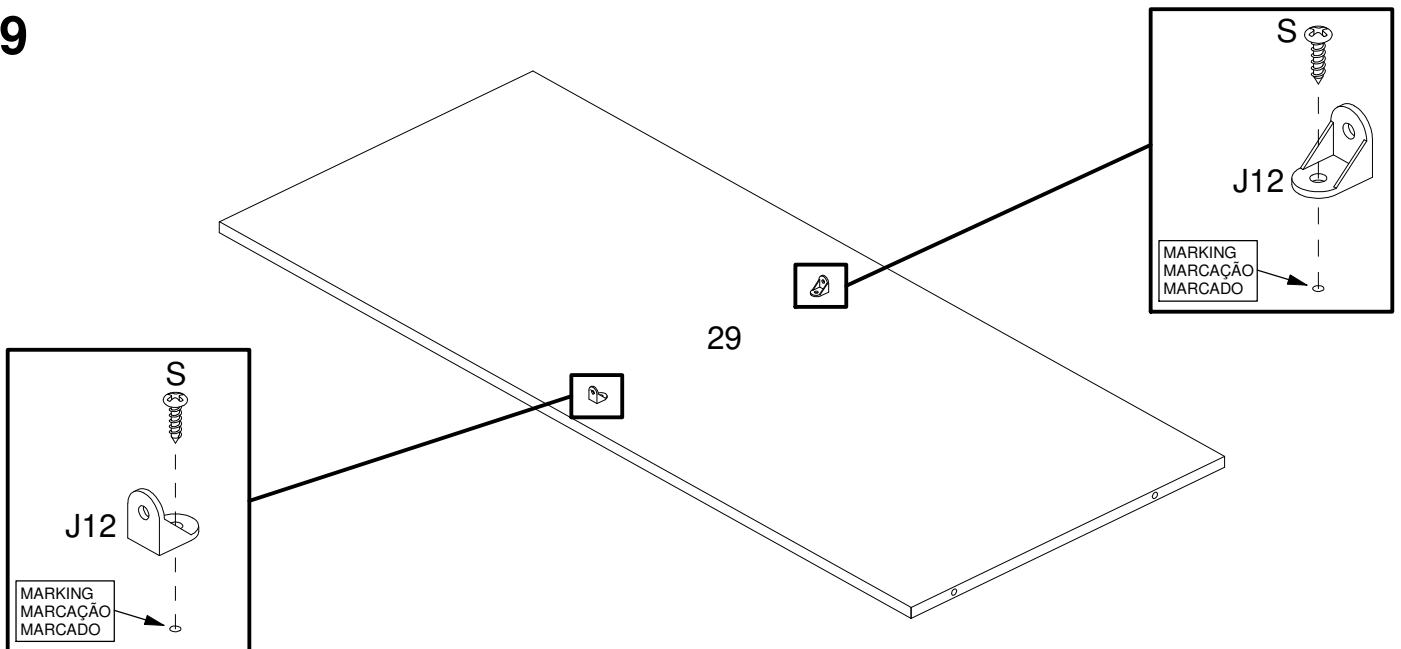

10

SEPARATE THE TWO PARTS OF THE METAL SLIDE TO THE ASSEMBLY FOLLOWING THE INSTRUCTIONS BELOW.
SEPARARE AS DUAS PARTES DA CORREDIÇA METÁLICA PARA A MONTAGEM SEGUINDO AS INSTRUÇÕES ABAIXO.
SEPARAR LAS DOS PARTES DE LA CORREDERA DE METAL PARA EL ARMADO Y SEGUIR A LAS INSTRUCCIONES ABAJO

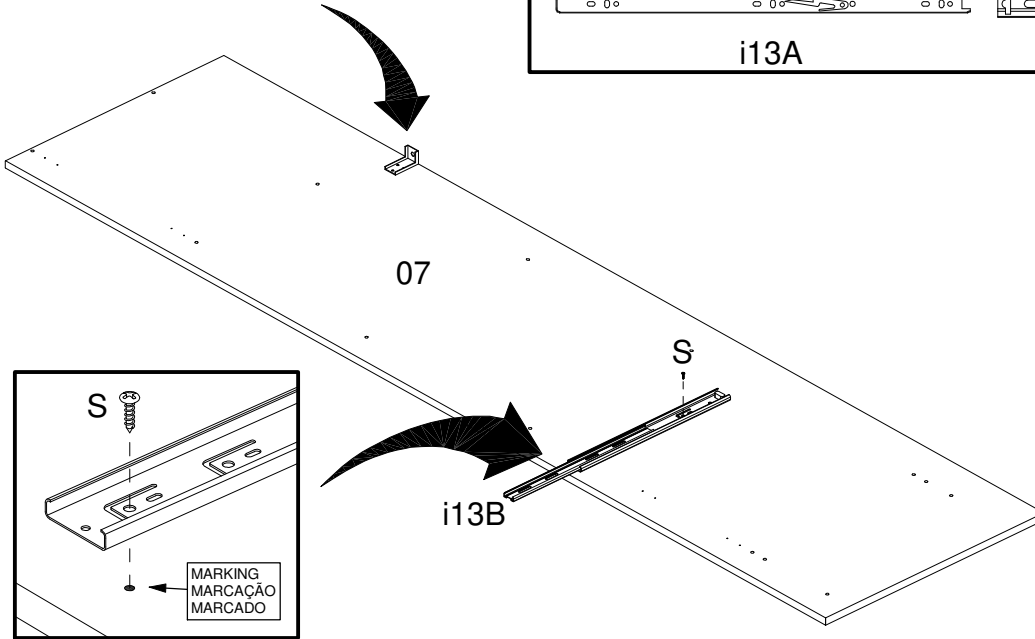
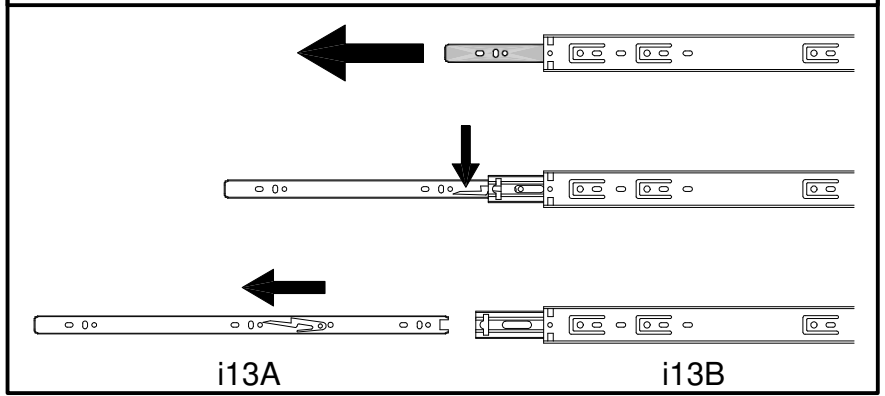
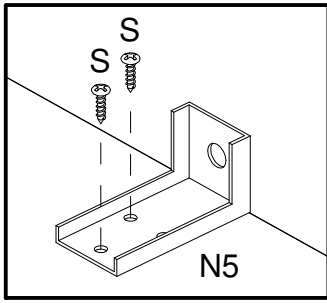

11

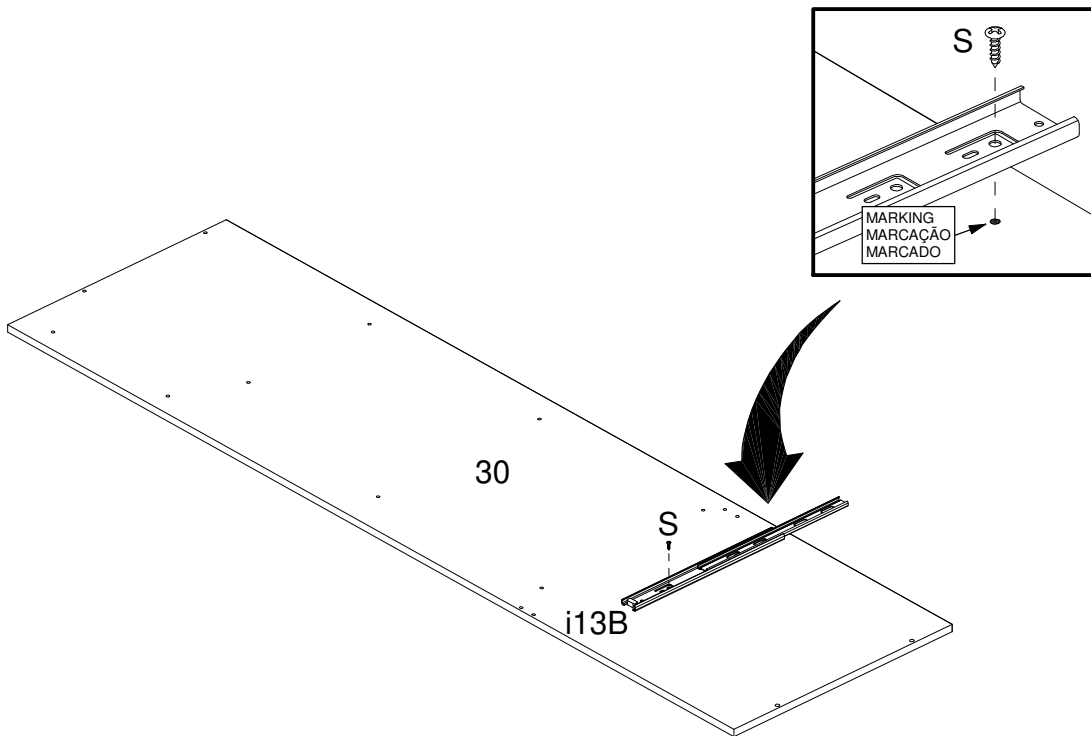

ASSEMBLY
MONTAGEM / ARMADO

12

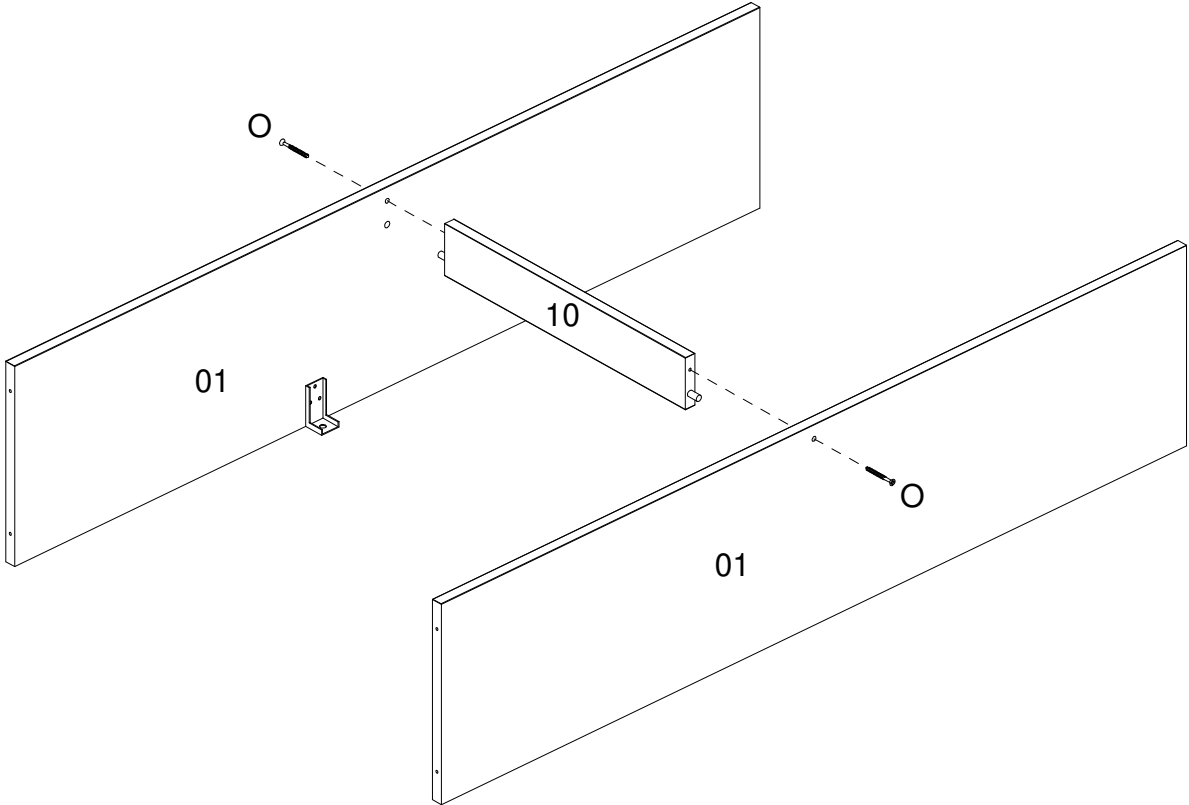

13

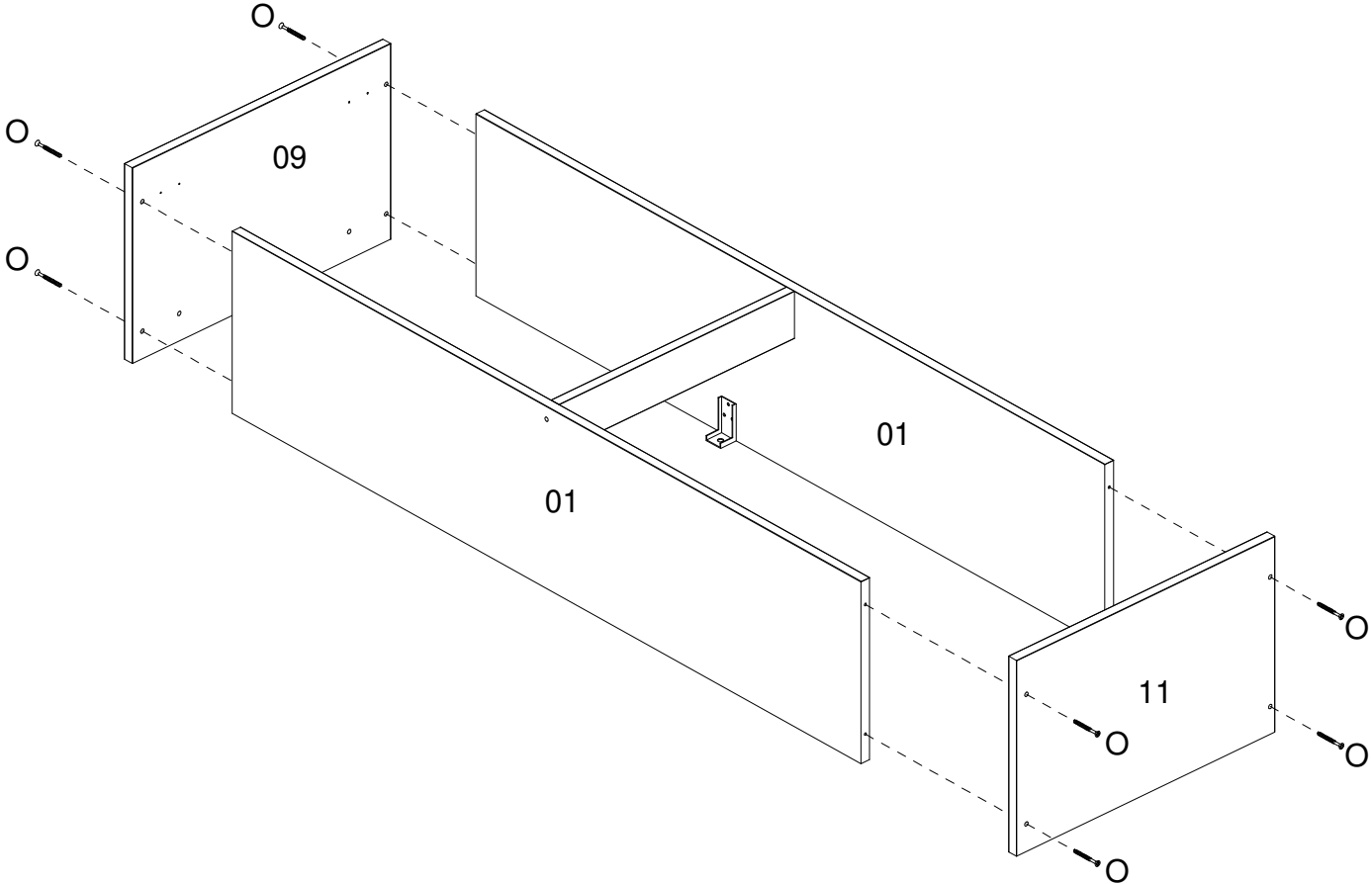

14

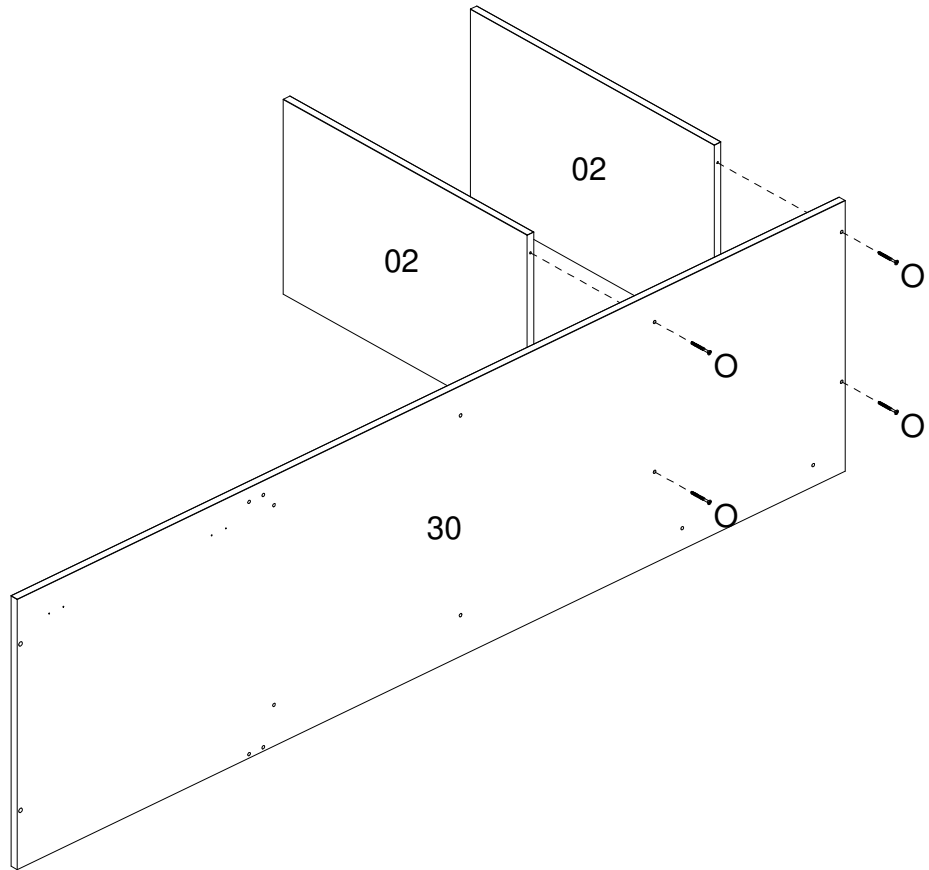

15

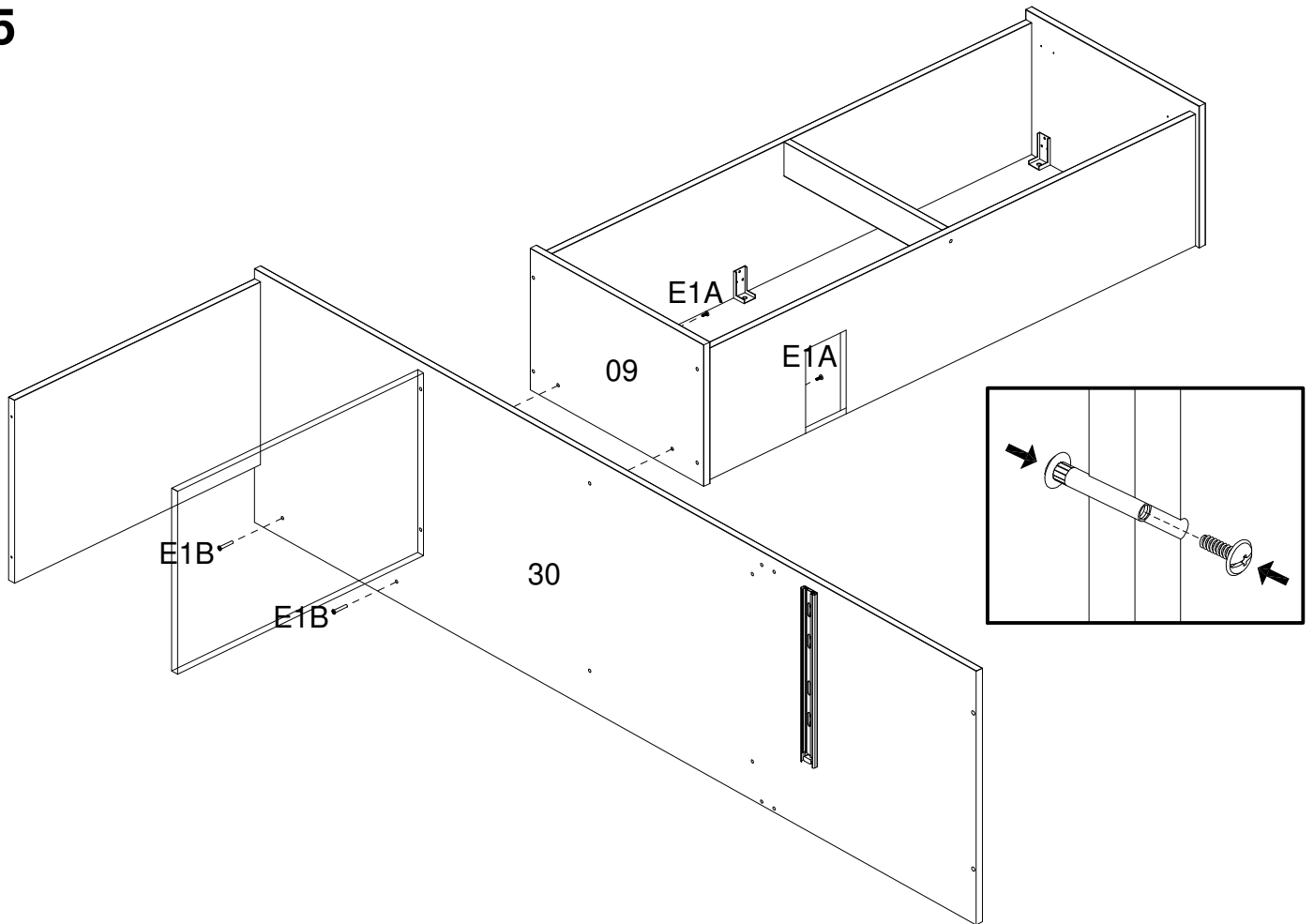

16

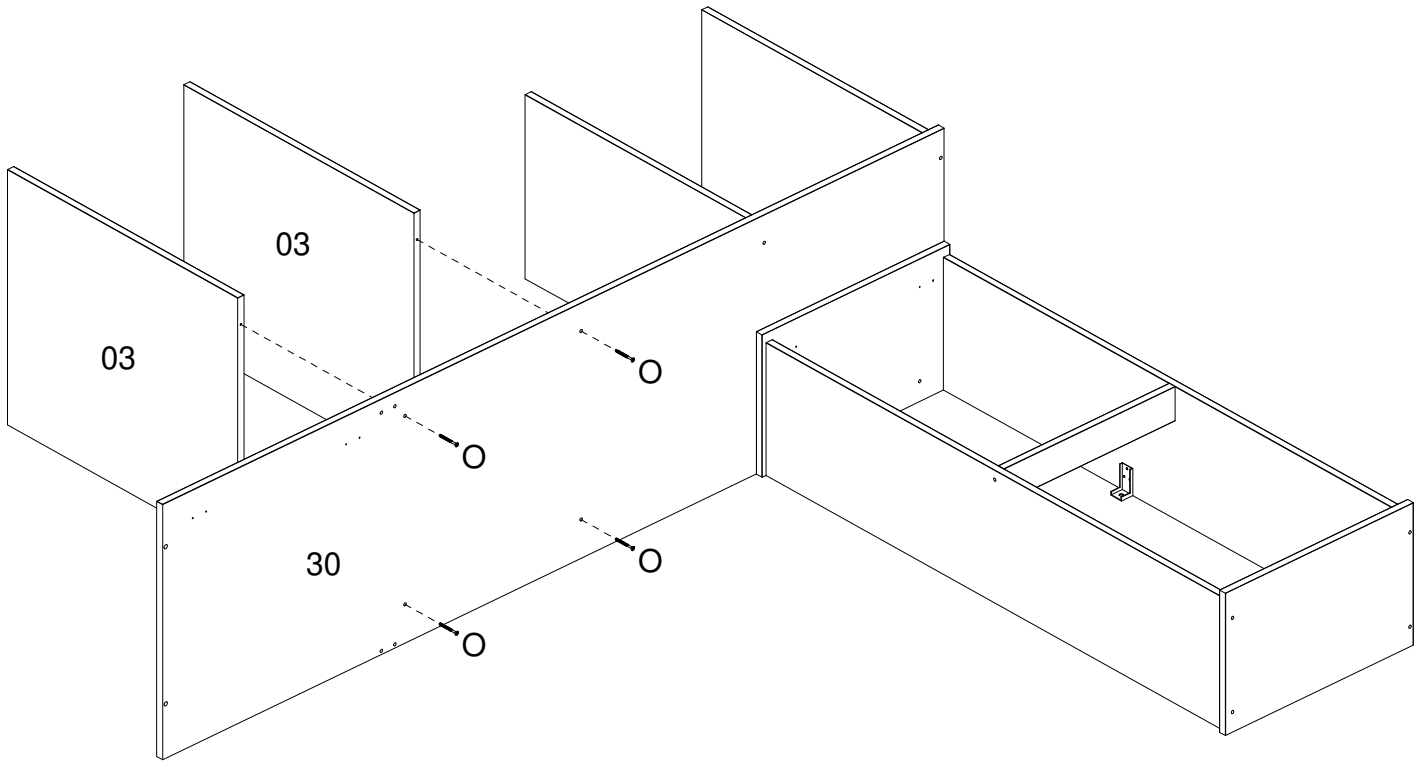

17

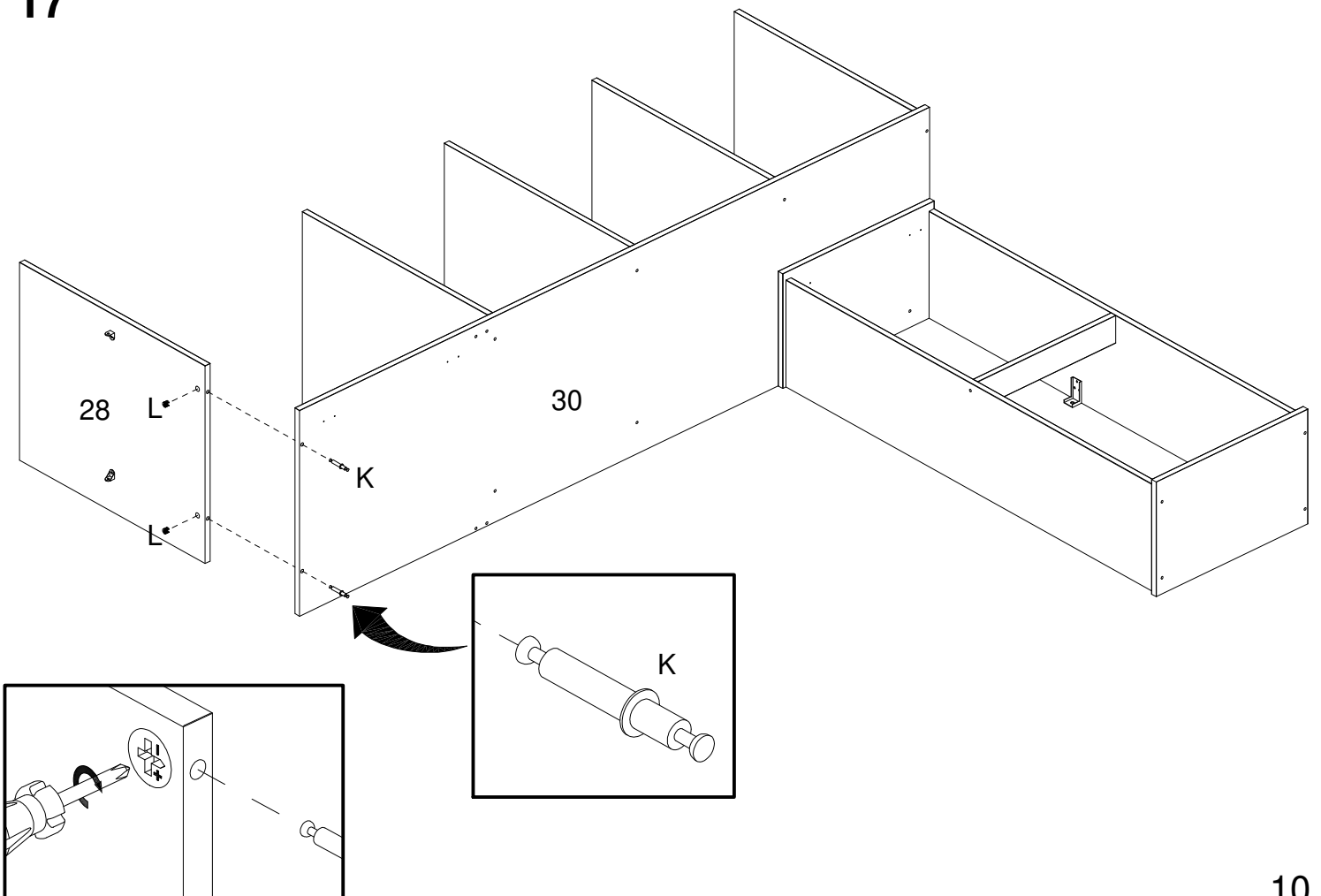

18

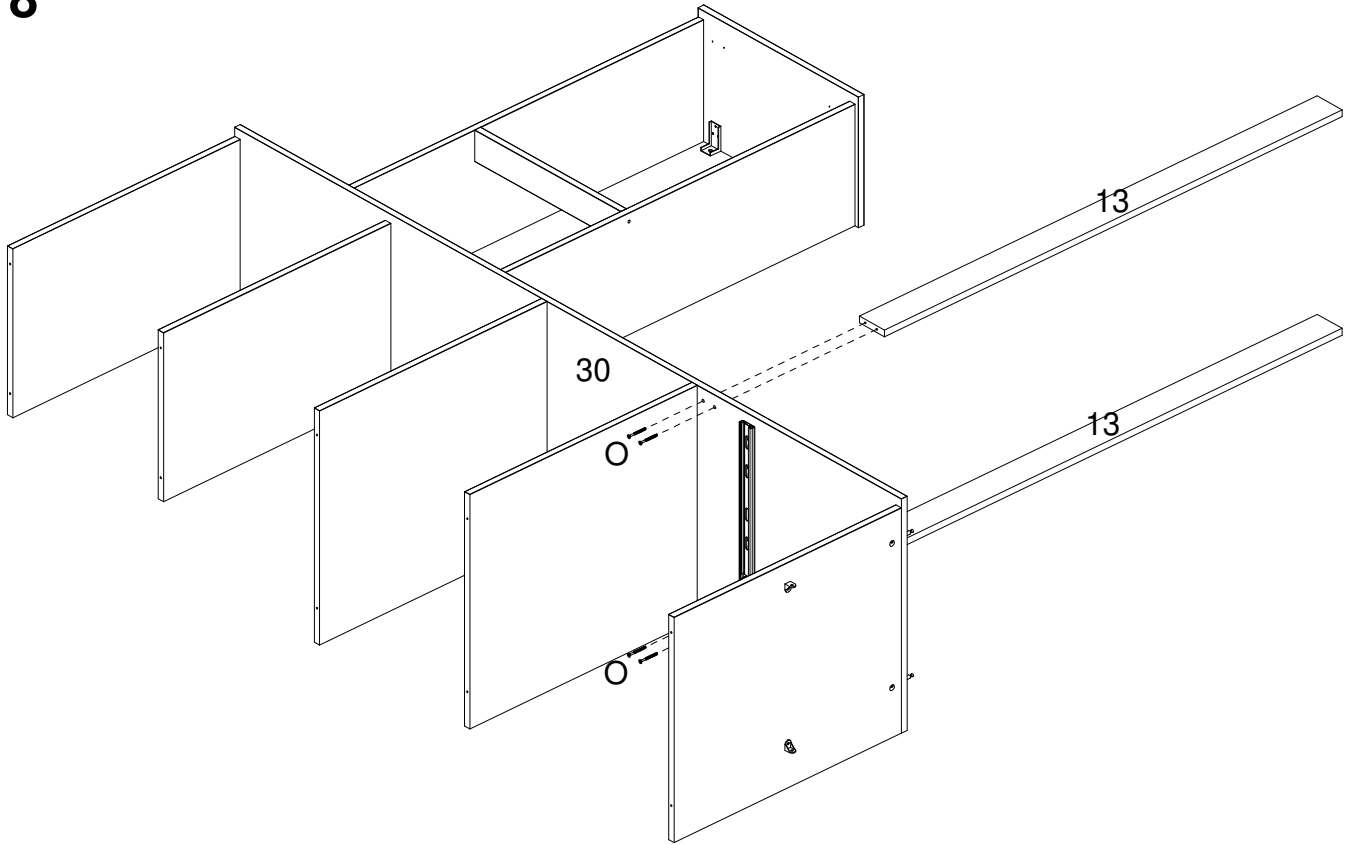

19

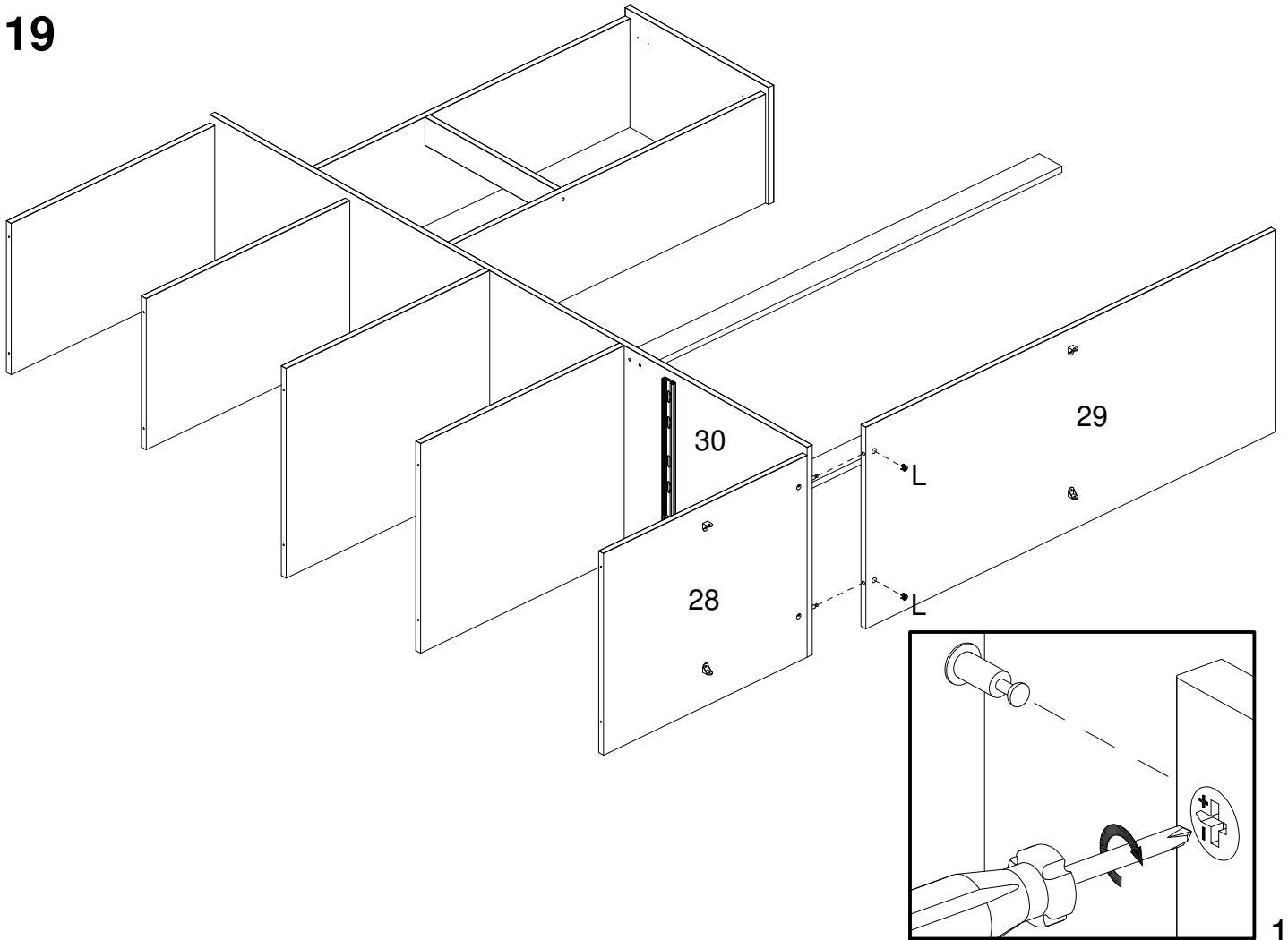

20

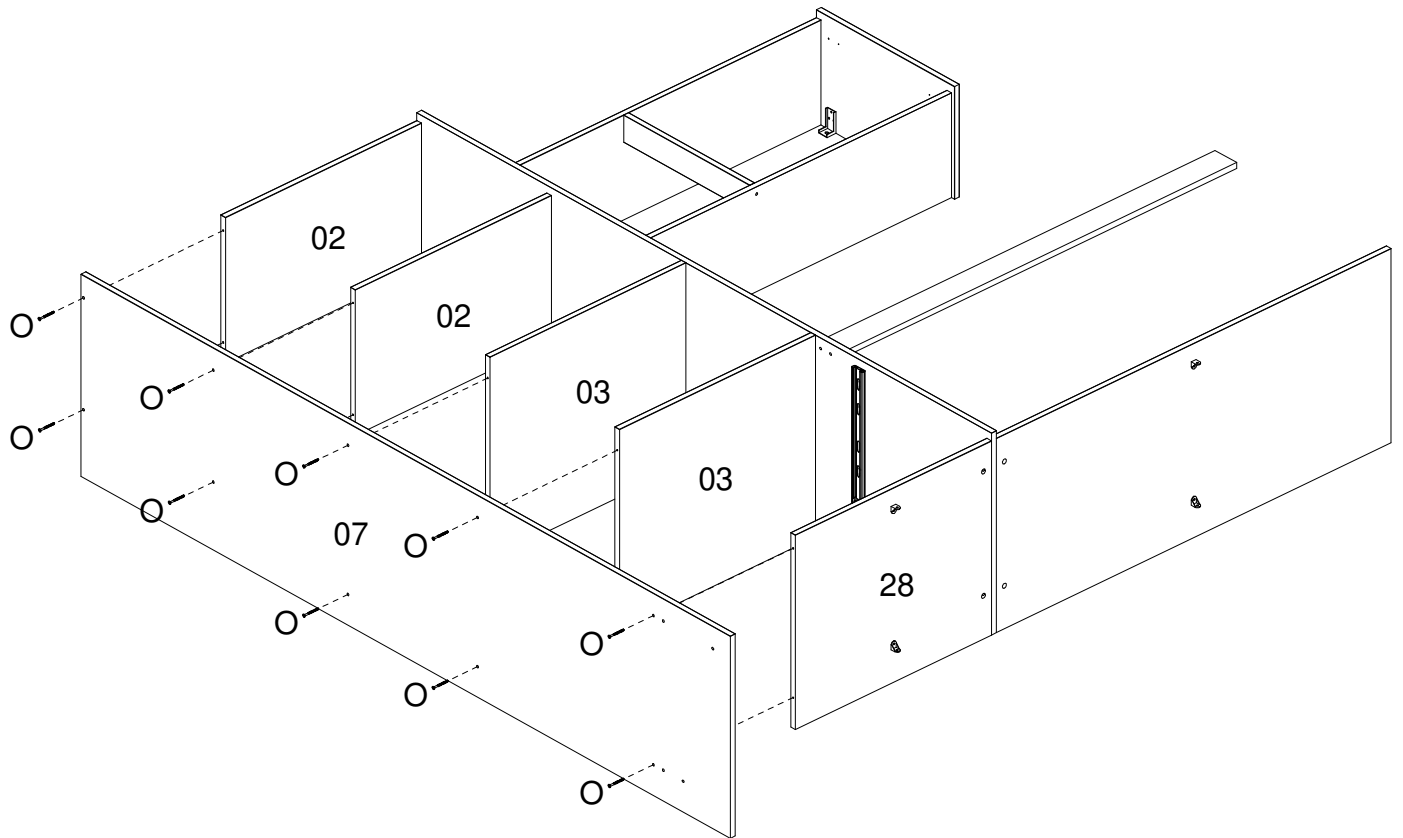

21

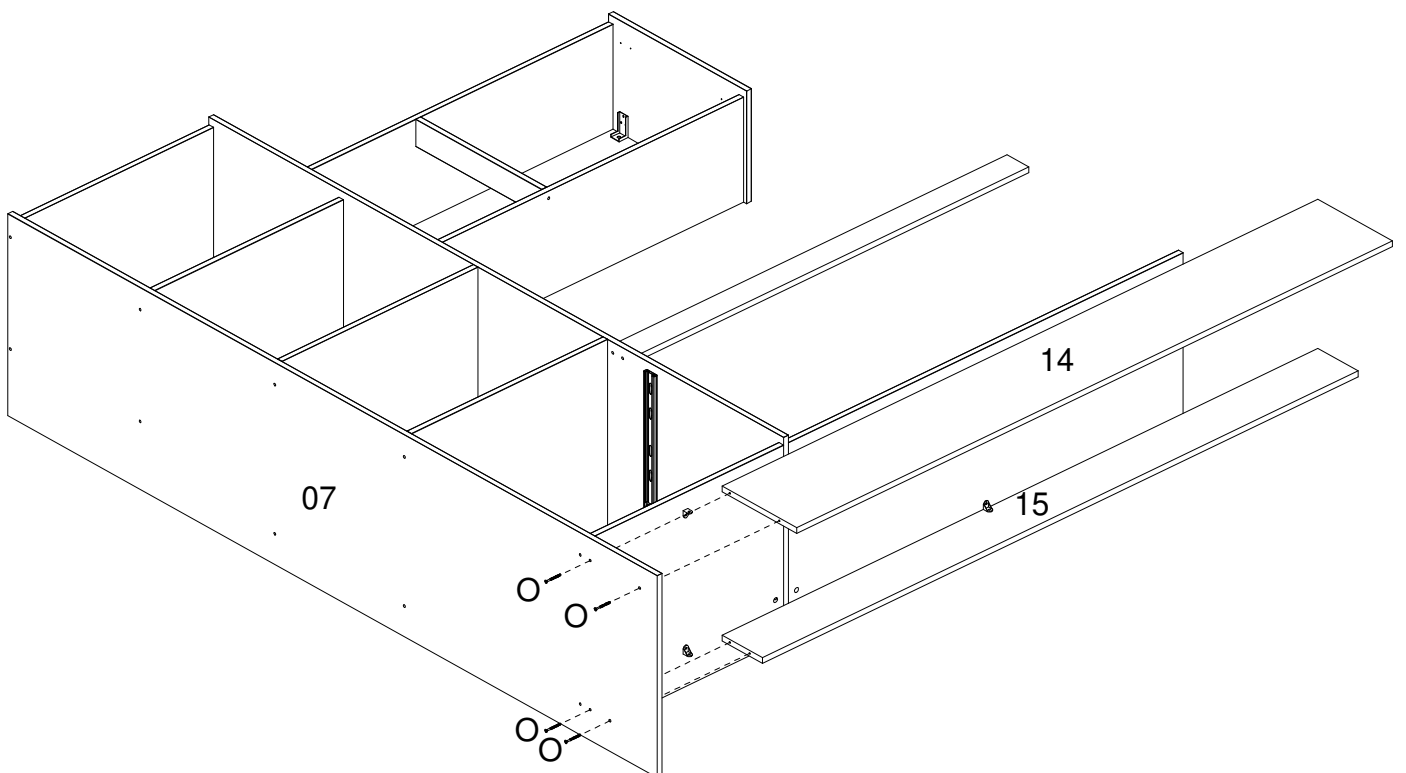

22

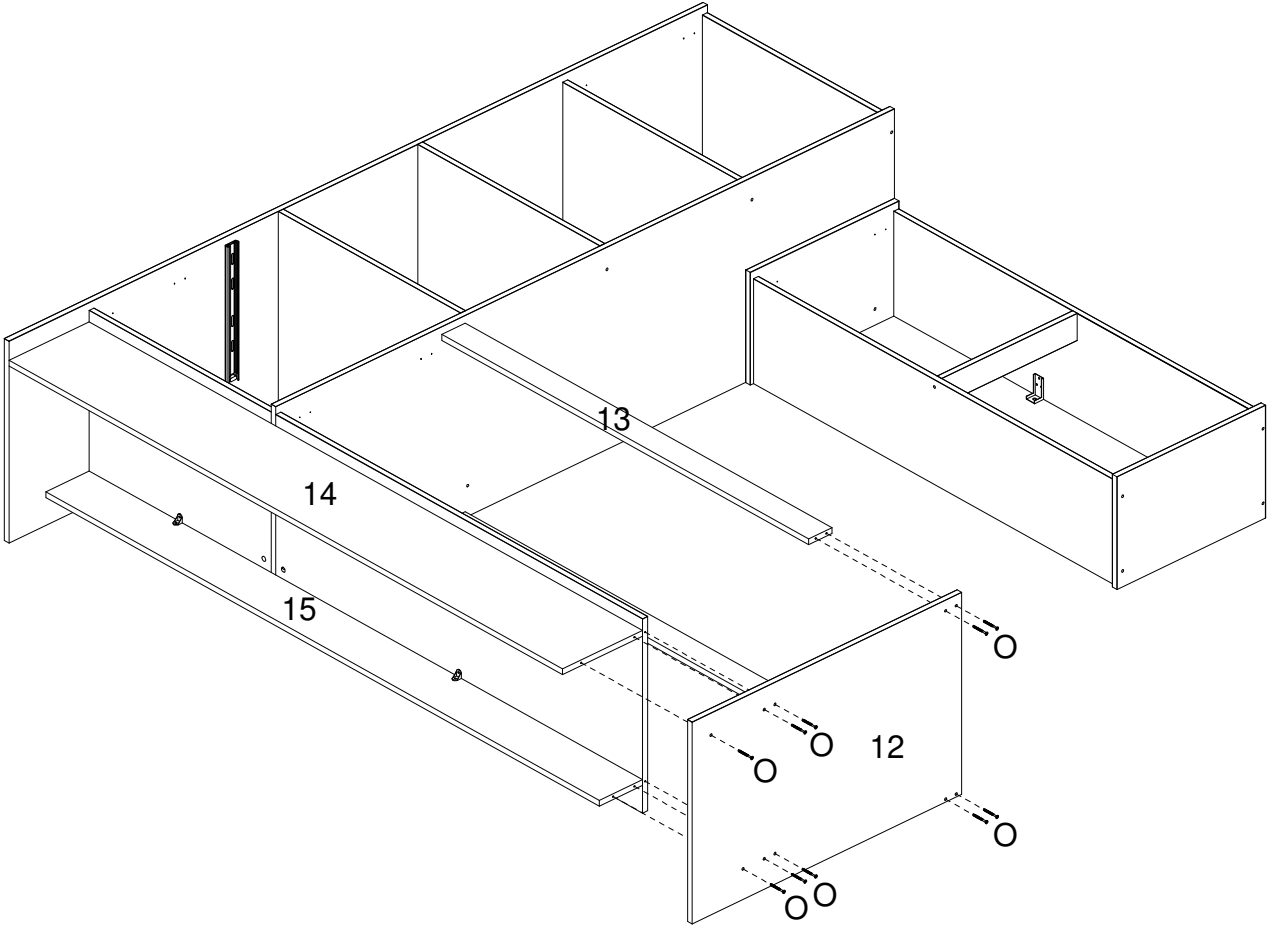

23

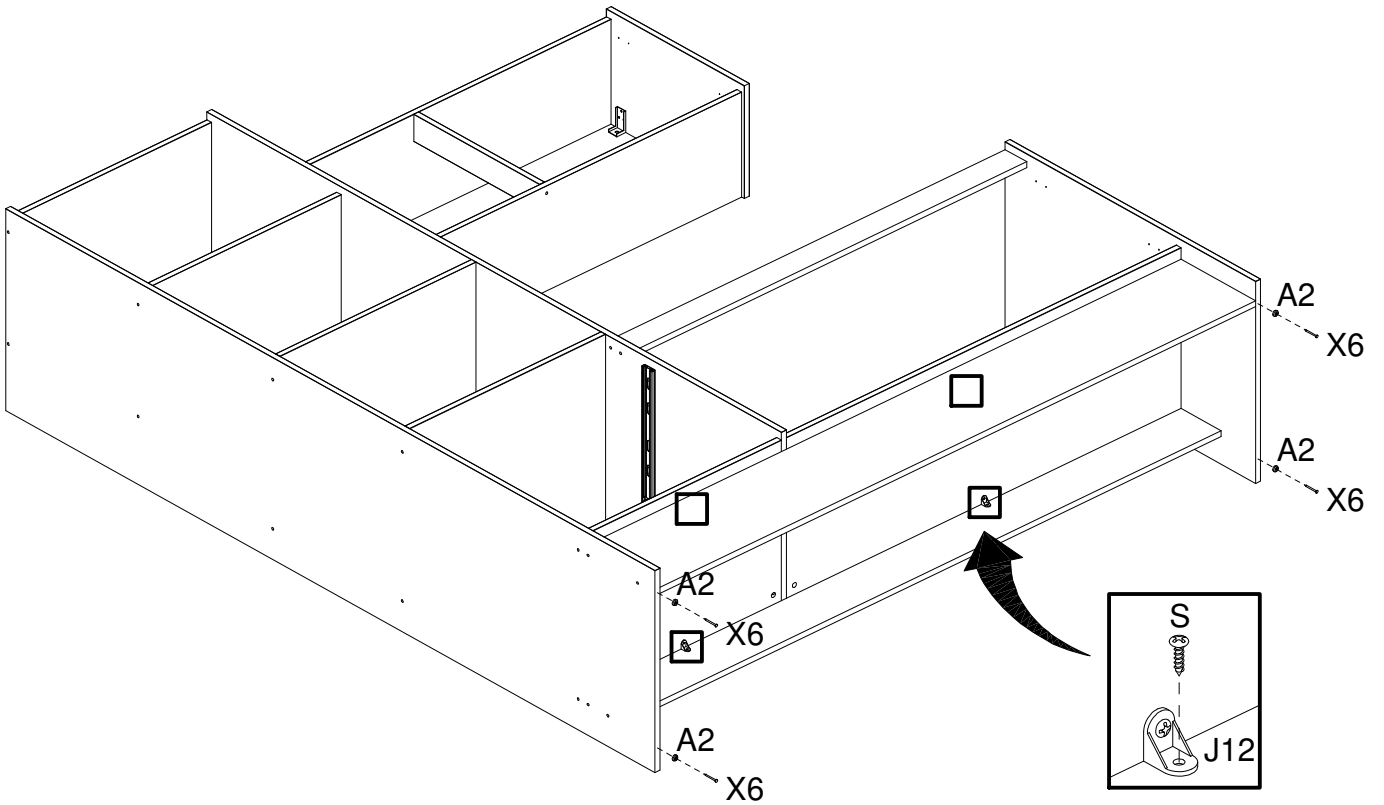

24

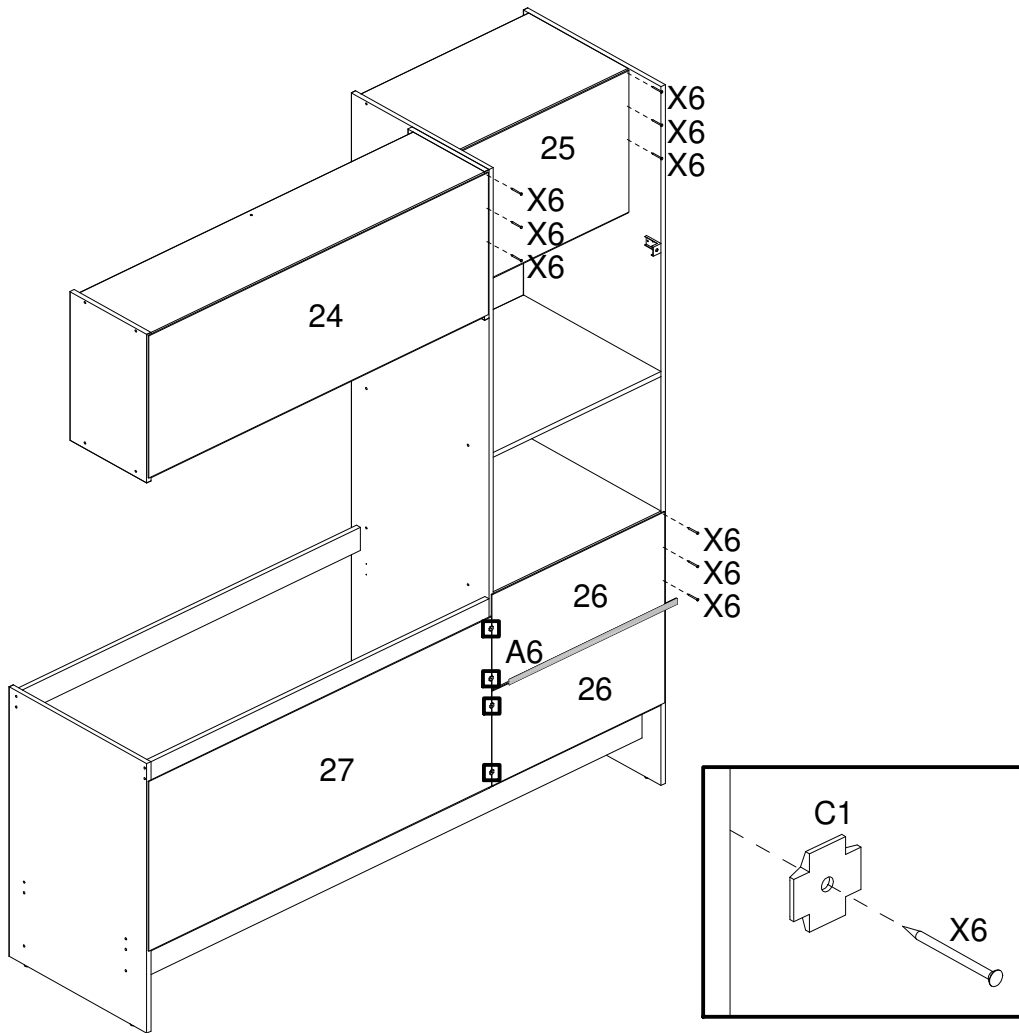

25

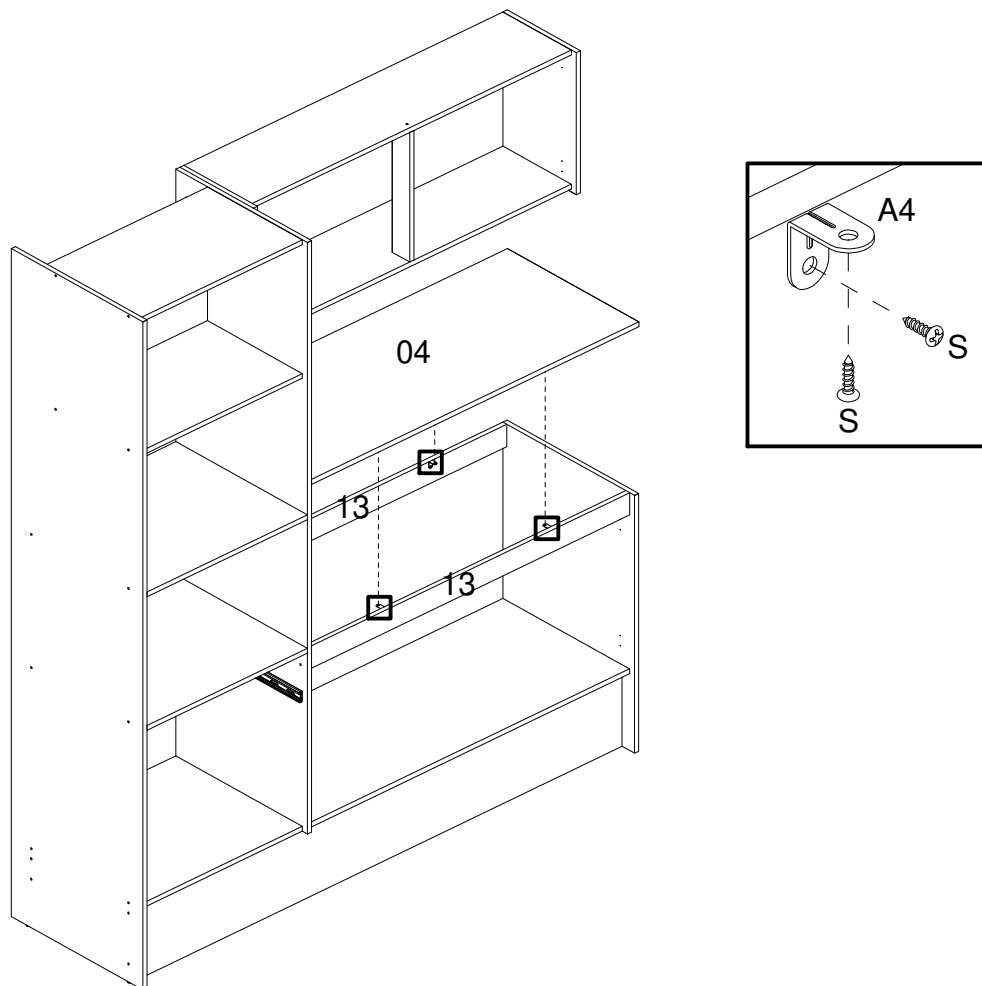

26

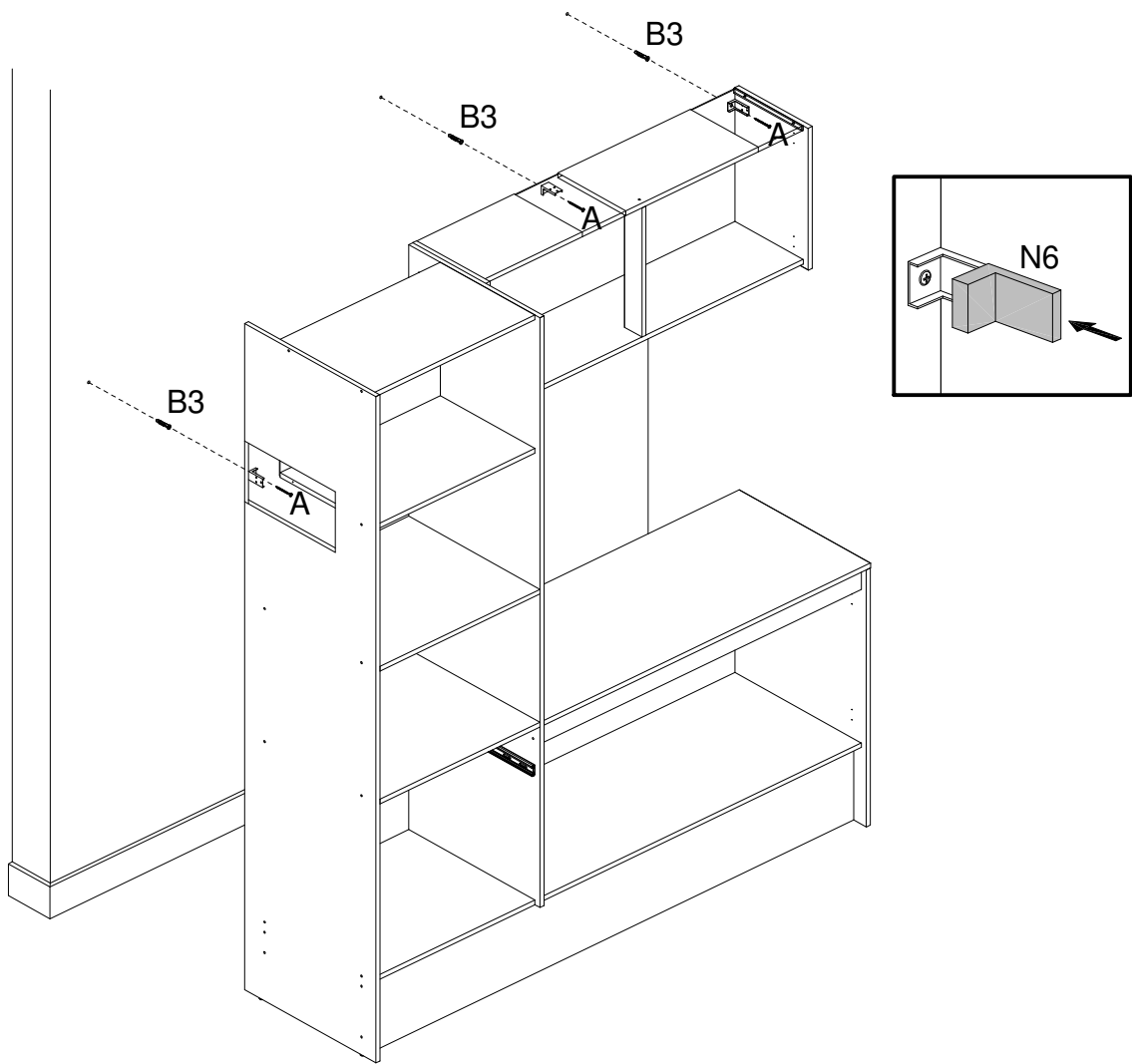

27

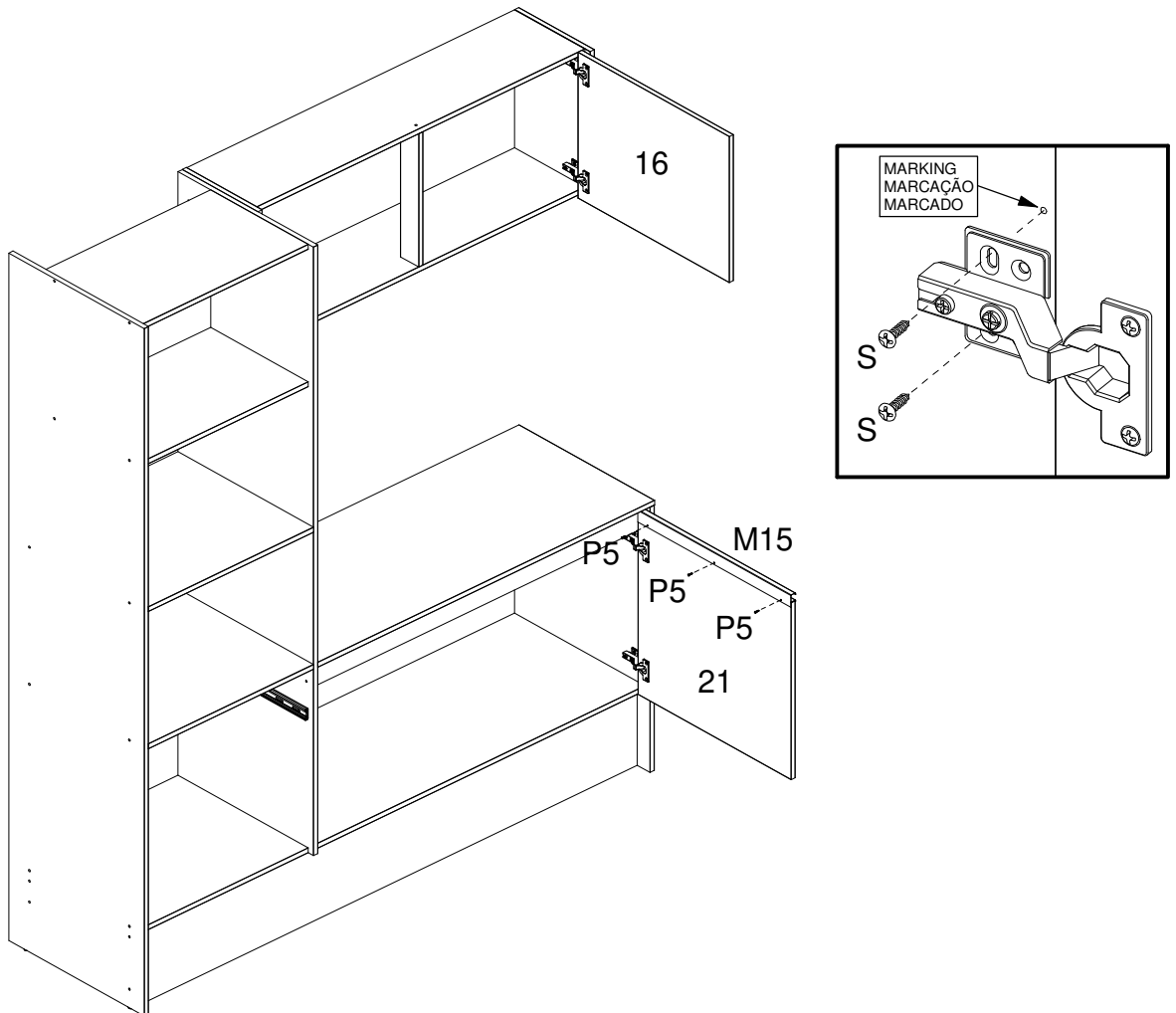

28

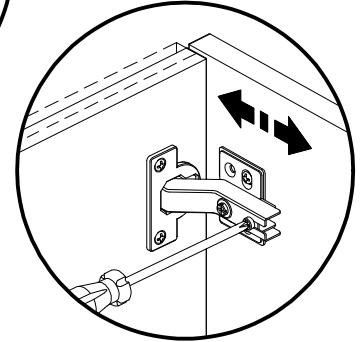
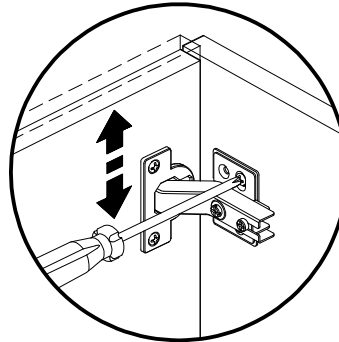
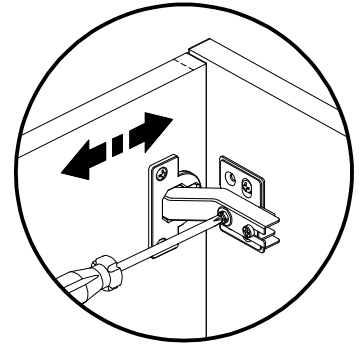
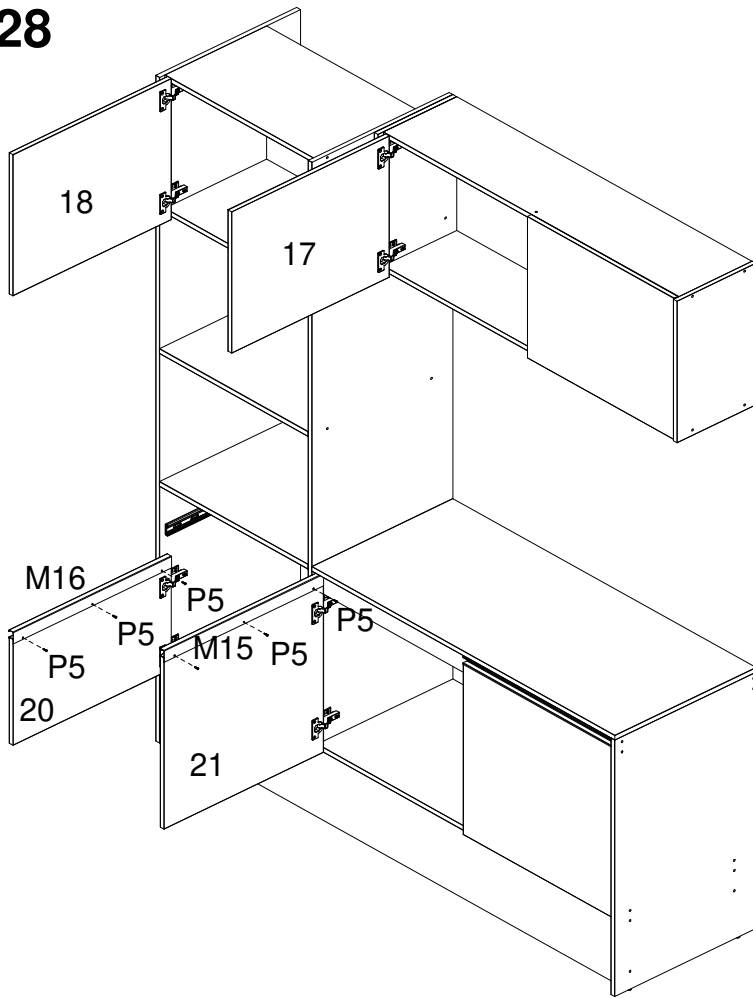

29

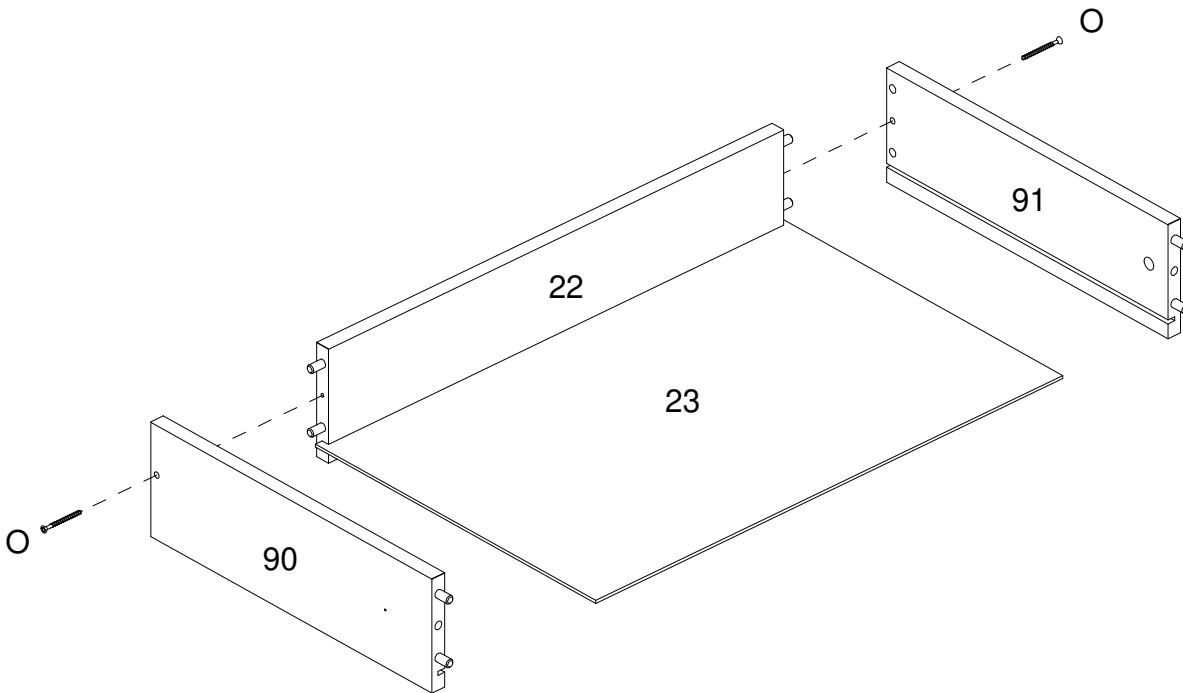

30

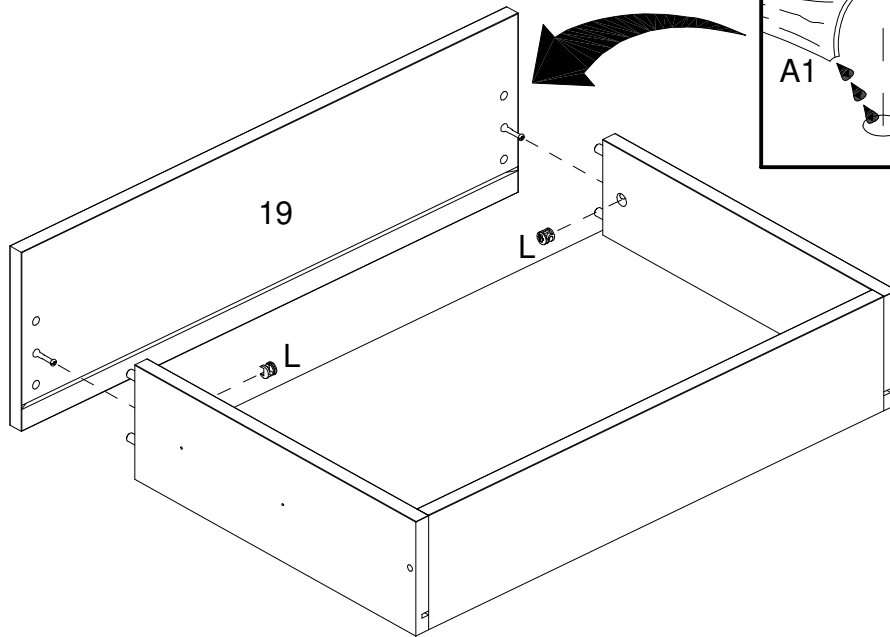
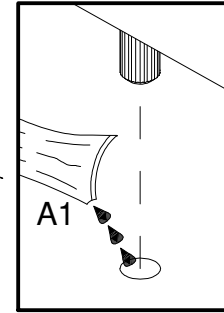
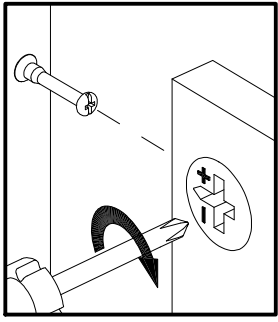

31

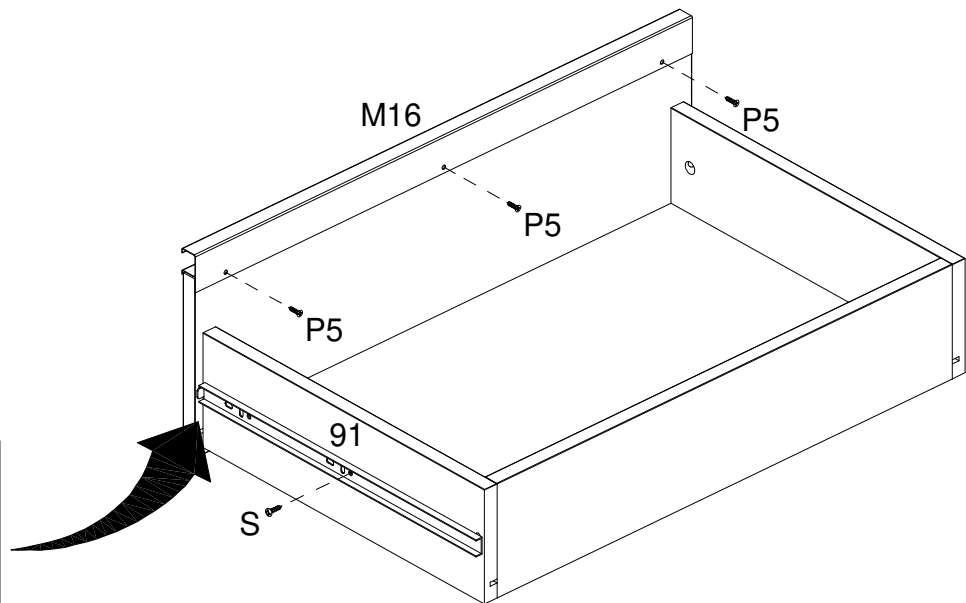
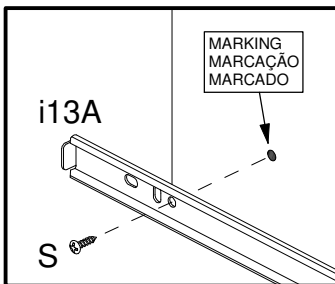

32

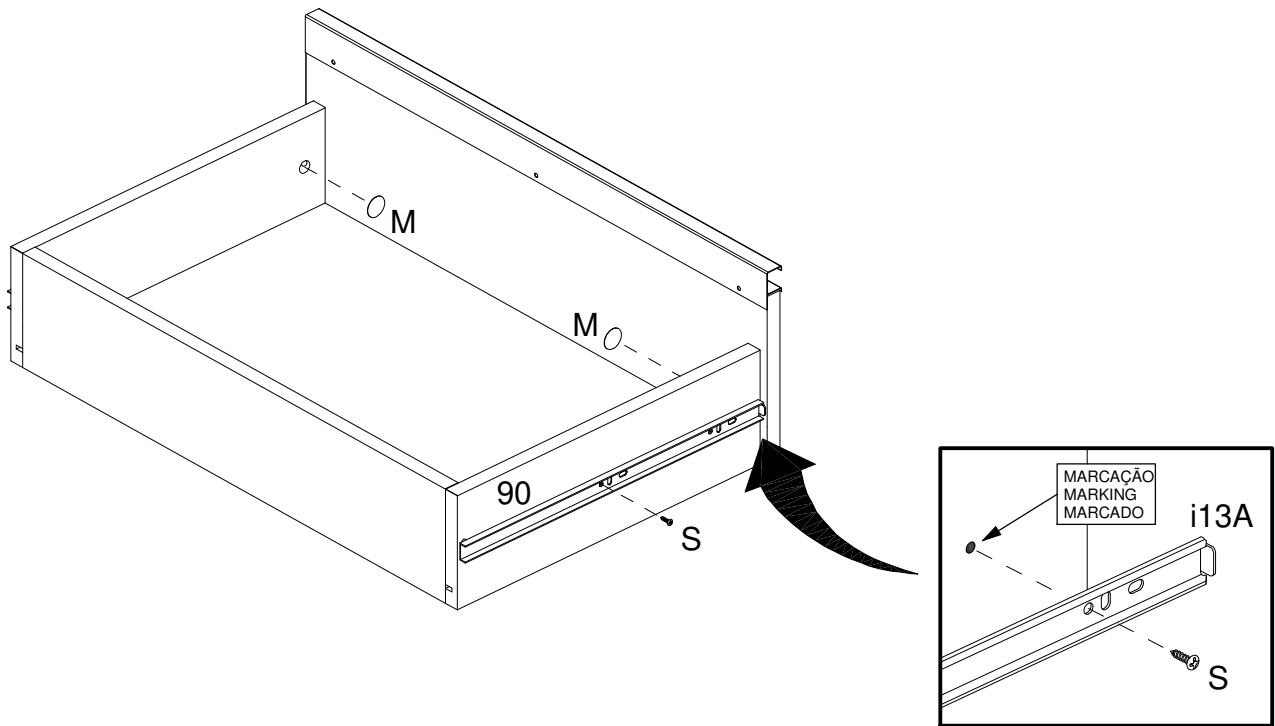

33

